

MERIT BADGE SERIES



BIRD STUDY



BOY SCOUTS OF AMERICA®



HOW TO USE THIS PAMPHLET

The secret to successfully earning a merit badge is for you to use both the pamphlet and the suggestions of your counselor.

Your counselor can be as important to you as a coach is to an athlete. Use all of the resources your counselor can make available to you. This may be the best chance you will have to learn about this particular subject. Make it count.

If you or your counselor feels that any information in this pamphlet is incorrect, please let us know. Please state your source of information.

Merit badge pamphlets are reprinted annually and requirements updated regularly. Your suggestions for improvement are welcome.

Send comments along with a brief statement about yourself to Youth Development, S209 • Boy Scouts of America • 1325 West Walnut Hill Lane • P.O. Box 152079 • Irving, TX 75015-2079.

WHO PAYS FOR THIS PAMPHLET?

This merit badge pamphlet is one in a series of more than 100 covering all kinds of hobby and career subjects. It is made available for you to buy as a service of the national and local councils, Boy Scouts of America. The costs of the development, writing, and editing of the merit badge pamphlets are paid for by the Boy Scouts of America in order to bring you the best book at a reasonable price.



BOY SCOUTS OF AMERICA
MERIT BADGE SERIES

BIRD STUDY



BOY SCOUTS OF AMERICA®

Requirements

1. Explain the need for bird study and why birds are useful indicators of the quality of the environment.
2. Show that you are familiar with the terms used to describe birds by sketching or tracing a perched bird and then labeling 15 different parts of the bird. Sketch or trace an extended wing and label six types of wing feathers.
3. Demonstrate that you know how to properly use and care for binoculars.
 - a. Explain what the specification numbers on the binoculars mean.
 - b. Show how to adjust the eyepiece and how to focus for proper viewing.
 - c. Show how to properly care for and clean the lenses.
4. Demonstrate that you know how to use a bird field guide. Show your counselor that you are able to understand a range map by locating in the book and pointing out the wintering range, the breeding range, and/or the year-round range of one species of each of the following types of birds:
 - a. Seabird
 - b. Plover
 - c. Falcon or hawk
 - d. Warbler or vireo

- e. Heron or egret
 - f. Sparrow
 - g. Nonnative bird (introduced to North America from a foreign country since 1800)
5. Observe and be able to identify at least 20 species of wild birds. Prepare a field notebook, making a separate entry for each species, and record the following information from your field observations and other references.
- a. Note the date and time.
 - b. Note the location and habitat.
 - c. Describe the bird's main feeding habitat and list two types of food that the bird is likely to eat.
 - d. Note whether the bird is a migrant or a summer, winter, or year-round resident of your area.
6. Explain the function of a bird's song. Be able to identify five of the 20 species in your field notebook by song or call alone. For each of these five species, enter a description of the song or call, and note the behavior of the bird making the sound. Note why you think the bird was making the call or song that you heard.
7. Do ONE of the following:
- a. Go on a field trip with a local club or with others who are knowledgeable about birds in your area.
 - (1) Keep a list or fill out a checklist of all the birds your group observed during the field trip.
 - (2) Tell your counselor which birds your group saw and why some species were common and some were present in small numbers.
 - (3) Tell your counselor what makes the area you visited good for finding birds.

- b. By using a public library or contacting the National Audubon Society, find the name and location of the Christmas Bird Count nearest your home and obtain the results of a recent count.
 - (1) Explain what kinds of information are collected during the annual event.
 - (2) Tell your counselor which species are most common, and explain why these birds are abundant.
 - (3) Tell your counselor which species are uncommon, and explain why these were present in small numbers. If the number of birds of these species is decreasing, explain why, and what, if anything, could be done to reverse their decline.
- 8. Do ONE of the following. For the option you choose, describe what birds you hope to attract, and why.
 - a. Build a bird feeder and put it in an appropriate place in your yard or another location.
 - b. Build a birdbath and put it in an appropriate place.
 - c. Build a backyard sanctuary for birds by planting trees and shrubs for food and cover.

Contents

Introduction	6
North America’s Birds	8
What Makes a Bird a Bird?	18
How Birds Live	28
Observing Birds	40
Bird Study and Science	58
Bird Conservation	64
Creating a Backyard Bird Sanctuary	74
Bird Study Resources	92

Introduction

In the spring of 1872, in a canyon in the Arizona wilderness, Major Charles Bendire—an Army officer who was deeply interested in birds—climbed a tall cottonwood tree, hoping to collect an egg from a zone-tailed hawk for the Smithsonian Institution. When he reached the nest, he noticed Apache Indians advancing on him. Not wanting the Apache to catch and perhaps kill him—but not wanting to lose the precious egg, either—Bendire popped it into his mouth. He then scrambled down the tree and rode off on his horse, eventually escaping the dozens of Indians who pursued him. Later, his men had to pry the unbroken hawk egg from his sore, cramped jaws.

Fortunately, studying birds today is not nearly as dangerous as it was in Major Bendire's day. (It is also now illegal to collect wild-bird eggs.) What was once

an unusual pastime has become one of the country's most popular and fastest-growing hobbies. More than 63 million Americans like to feed and watch birds in their backyards; more than 27 million consider themselves active *birders*. They avidly search for species to add to their *life lists*, take part in competitive birding activities like Big Days, help scientists study wild-bird populations, or just relax outdoors with a pair of binoculars and a field guide. Some are professional *ornithologists*—scientists who study birds.



Birds are among the most fascinating creatures on Earth. Many are beautifully colored. Others are accomplished singers. To us their behavior seems, at times, utterly bizarre—like the way prairie-chickens inflate colorful air sacs on their necks and dance for their mates, or the dipper’s habit of walking beneath raging mountain streams to find insects. But most intriguing of all, birds can fly—a talent that has made humans envious for thousands of years. We can travel in planes, of course, but people simply can’t compete with a peregrine falcon diving at more than 200 miles per hour, or a tiny hummingbird hovering on wings that beat more than 80 times each second.

Keep your eyes open. You often will be surprised by unusual behavior among even the most common, familiar birds. In fact, many of the most important discoveries about birds and how they live have been made by amateur birders. In pursuing this hobby, you might someday make a valuable contribution to our understanding of the natural world.



Birds are found almost everywhere, from the middle of large cities to the most remote wilderness areas and far out on the open oceans. You can go birding in your backyard and on vacation, spotting exciting species whenever you travel to new areas. With more than 9,000 species of birds in the world, birding is a hobby that can last a lifetime.

You can start a *life list*—a tally of all the species of birds you see—including the date and place where you saw each one. Years from now, a life list can help you relive the exciting moment when you saw a new species—a life bird.

North America's Birds

To find out more about habitats, communities, and ecosystems, see the *Environmental Science* merit badge pamphlet.

More than 800 species of birds breed in North America or appear here regularly in migration. The list ranges from the enormous (and critically endangered) California condor, with a wingspan of more than 9 feet, to the tiny calliope hummingbird of the West, which is just a bit longer than 3 inches and weighs less than a 10th of an ounce. Some species are found almost everywhere, such as the American robin, which occurs in every state except Hawaii. Others have extremely small ranges. If you want to see a Colima warbler, for example, you will have to climb high into the Chisos Mountains of southwest Texas. The only place in the United States where you can see a white-crowned pigeon is the Florida Keys.

One reason North America has so many species of birds is that the continent has many different *habitats*, each of which can support a different *community* of plants and animals. The kinds of birds that can survive on the edge of the Arctic Ocean in Alaska, where the sun barely shines all winter, will be much different from those found in a cypress swamp in the Southeast, on a prairie in the Great Plains, or in a redwood forest along the Pacific Coast. You can learn more about which birds are found in different habitats in the section titled "Where to Find Birds" later in this chapter.



Birds come in a variety of shapes and sizes, such as in the California condor, left, and calliope hummingbird.

Birds lend life, color, and music to the outdoors, and they are an important part of the ecosystems that keep this planet healthy. Because they are sensitive to changes in the environment, birds are valuable indicators of trouble, including pollution and habitat loss. It was the near-disappearance of bald eagles, peregrine falcons, and brown pelicans decades ago that alerted people to the dangers of many pesticides. Major, rapid declines in the number of songbirds have shown that we must preserve large areas for wildlife habitat.

How Birds Are Classified

Scientists group living things by how closely they are related to one another. Each *species* is lumped with its closest relatives to form a *genus*, usually on the basis of physical characteristics like the shapes of certain bones. Closely related *genera* (the plural of “genus”) are grouped together to form a *family*. Similar families make up the 20 *orders* of birds in North America, all of which belong to the class *Aves*, from the Latin word meaning “birds.”

As you learn about birds, knowing how they are classified will help you in many ways. Most field guides are arranged in this *taxonomic order*. Because related birds often act and look somewhat the same, knowing these relationships can help you identify a new, puzzling species.

Increasingly, scientists have been using molecular genetics to classify birds. It's a very complicated process that involves the use of genetic information to help determine a species' or group's place in the overall taxonomic order. Thanks to molecular genetics, the New World vultures are now considered close relatives of the storks. (See the box titled “American Bird Orders.”)

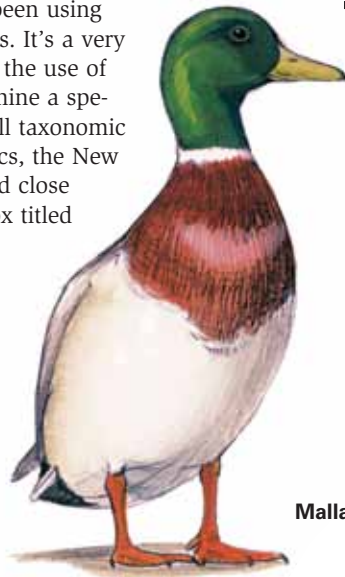

Mallard

In years past, coal miners took caged canaries underground because invisible poisonous gases would kill the birds first, warning the men and allowing them to escape. In a sense, wild birds are often our “canaries in the mine.”



1



2



3



4



5



6



7



8



9



10

American Bird Orders

The bird orders found in North America are shown below, with some of the common families listed in the order. Some orders, like the Gaviiformes (loons) and Podicipediformes (grebes), have only one family, whereas the order Passeriformes, the perching birds, has dozens of families.

1. **Gaviiformes.** Loons: Gooselike waterbirds that dive for fish.
2. **Podicipediformes.** Grebes: Ducklike waterbirds with lobed toes.
3. **Procellariiformes.** Albatrosses, petrels, shearwaters: These sea birds have tubelike nostrils.
4. **Pelecaniformes.** Pelicans, frigatebirds, cormorants: Fish-eating birds with all four toes webbed.
5. **Anseriformes.** Ducks, geese, swans, and other waterfowl.
6. **Ciconiiformes.** Herons, storks: Long-legged wading birds. (New World vultures have also recently been identified as belonging to this order, although they have short legs and look like hawks.)
7. **Falconiformes.** Hawks, eagles, ospreys, falcons: Day-hunting birds of prey.
8. **Galliformes.** Grouse, quail, pheasants, turkeys: *Gallinaceous* (chickenlike), ground-dwelling birds.
9. **Gruiiformes.** Cranes, rails, coots: A varied group of land and marsh birds.
10. **Charadriiformes.** Gulls, terns, auks, sandpipers: A large order of waterbirds and shorebirds.

11. **Columbiformes.** Doves, pigeons: Plump, small-headed, powerful fliers.
12. **Psittaciformes.** Parrots: Rare in the United States, except as escapees from captivity.
13. **Cuculiformes.** Cuckoos, roadrunners: Long, slender birds with two toes that point forward and two that point backward.
14. **Strigiformes.** Owls: Night-hunting birds of prey.
15. **Caprimulgiformes.** Nightjars, frogmouths: These birds have tiny feet, small bills, and huge, gaping mouths.
16. **Apodiformes.** Swifts, hummingbirds: Small, strong-winged, spectacular fliers.
17. **Trogoniformes.** Trogons: Tropical birds rare in the United States.
18. **Coraciiformes.** Kingfishers: Short-tailed birds with long, stout, sharp bills.
19. **Piciformes.** Woodpeckers: Tree-climbers that drill into trees with long, chisel-like bills.
20. **Passeriformes.** Perching birds: The largest order of birds in the world, including more than half of all living bird species. Perching birds (also called *passerines*) include flycatchers, shrikes, vireos, crows and jays, waxwings, dippers, thrushes, thrashers, nuthatches, creepers, wrens, gnatcatchers, titmice and chickadees, swallows, kinglets, wood warblers, longspurs, sparrows, towhees, tanagers, grosbeaks, orioles, robins, and blackbirds.



11



12



13



14



15



16



17



18



19



20

Where to Find Birds

Bird species are found in their favorite habitat—the mix of terrain and plants in which they prefer to live. The terrain and plant life of this habitat in turn support the preferred food sources and hiding and nesting surroundings the bird needs. Some birds need a marshy habitat; others inhabit conifer forests or grasslands. By knowing where to look, you will increase your odds of having an exciting day of birding. Eventually, you should be able to look at a particular habitat and make an accurate guess as to what kinds of birds you are likely to see there.



Certain habitats are especially good for many species. Wetlands are near the top of the list. Marshes, swamps, prairie potholes, bogs, and other damp places attract many bird types found nowhere else. But every habitat has its particular kinds of birds, and often the best birding is where two or more habitats meet—what ecologists call an *ecotone*.

Listed below are some of the most common species of birds in each habitat. These lists are far from complete. You may find many species that are not listed here. Also remember that birds often use more than one kind of habitat. An adaptable species like the mourning dove may be found in backyards, city parks, farmlands, or prairies, and gulls are often found far from lakes or oceans.





American robin



Common yellowthroat



Western meadowlark



Clark's nutcracker



Ruffed grouse

Backyards and Parks

Canada goose, mallard, mourning dove, common night-hawk, chimney swift, American crow, blue jay, northern flicker, black-capped and Carolina chickadees, American robin, eastern bluebird, northern mockingbird, European starling, house sparrow, northern cardinal, chipping sparrow, house finch, Brewer's blackbird (West), common grackle (East)

Roadsides, Thickets, and Brushy Areas

Cooper's hawk, northern bobwhite, California quail (West), yellow-billed cuckoo, mourning dove, willow flycatcher, black-billed magpie (West), house wren, brown thrasher, gray catbird, Bell's vireo, white-eyed vireo, orange-crowned warbler (West), yellow warbler, common yellowthroat, northern cardinal, pyrrhuloxia (Southwest), spotted towhee (West), eastern towhee, song sparrow, white-throated sparrow

Fields, Meadows, and Prairies

Killdeer, upland sandpiper, turkey vulture, northern harrier, red-tailed hawk, Swainson's hawk (West), American kestrel, sharp-tailed grouse, ring-necked pheasant, mourning dove, short-eared owl, eastern kingbird, western kingbird, scissor-tailed flycatcher (Great Plains), American crow, horned lark, barn swallow, loggerhead shrike, mountain bluebird (West), grasshopper sparrow, vesper sparrow, Savannah sparrow, lark sparrow, dickcissel, eastern and western meadowlarks, American goldfinch

Western Mountains

Harlequin duck, golden eagle, blue grouse, white-tailed ptarmigan, spotted owl, calliope hummingbird, broad-tailed hummingbird, Williamson's and red-naped sapsuckers, Clark's nutcracker, northern raven, mountain chickadee, pygmy nuthatch, American pipit, American dipper, Townsend's warbler, white-crowned sparrow, western tanager, gray-crowned rosy finch, black rosy finch

Deciduous Eastern Hardwood Forests

Red-shouldered hawk, broad-winged hawk, ruffed grouse, wild turkey, great horned owl, eastern screech owl, ruby-throated hummingbird, downy woodpecker, pileated

woodpecker, eastern phoebe, great-crested flycatcher, blue jay, tufted titmouse, white-breasted nuthatch, wood thrush, red-eyed vireo, black-and-white warbler, ovenbird, American redstart, rose-breasted grosbeak, dark-eyed junco, Baltimore oriole, scarlet tanager

Conifer Forests

Northern goshawk, spruce grouse, northern saw-whet owl, great gray owl, red-cockaded woodpecker (Southeast), olive-sided flycatcher, Hammond's flycatcher (West), Steller's jay (West), gray jay (North and the Rockies), northern raven, red-breasted nuthatch, brown-headed nuthatch (Southeast), winter wren, golden-crowned kinglet, hermit thrush, varied thrush (West), Cape May warbler, pine warbler, pine siskin, red crossbill, white-winged crossbill, purple finch

Deserts and Arid Scrub

Turkey vulture, red-tailed hawk, Harris' hawk, scaled quail, Gambel's quail, white-winged dove, greater roadrunner, elf owl, burrowing owl, common poorwill, Costa's hummingbird, Gila woodpecker, ladder-backed woodpecker, cactus wren, rock wren, canyon wren, curve-billed thrasher, gray vireo, black-throated sparrow, sage sparrow, rufous-crowned sparrow

Freshwater Wetlands and Lakes

Common loon, pied-billed grebe, white pelican, double-crested cormorant, American bittern, green heron, great blue heron, white-faced ibis (West), sandhill crane, Canada goose, mallard, northern pintail, blue-winged teal, sora, American coot, American avocet, killdeer, greater and lesser yellowlegs, spotted sandpiper, ring-billed gull, Forster's tern, black tern, osprey, bald eagle, belted kingfisher, tree swallow, marsh wren, red-winged blackbird, yellow-headed blackbird (West)

Coastal Wetlands and Seashores

Brown pelican, tricolored heron, reddish egret (South), white ibis, clapper rail, American oystercatcher, semipalmated plover, black-bellied plover, willet, short-billed and long-billed dowitchers, sanderling, laughing gull (East and South), herring gull, western gull, common tern, black skimmer, fish crow (East), seaside sparrow, boat-tailed grackle



Saw-whet owl



Harris' hawk



Great blue heron



Common tern

Nonnative Birds

Some of North America's most common birds were brought to this continent by humans. Over the years, and for a variety of reasons, people have released dozens of different bird species in the United States. Some have escaped from captivity—ducks, pheasants, quail, parrots, songbirds, and even emus (relatives of the ostrich), which have escaped from ranches, especially in Texas. Most of these introductions have failed, but a few species have become widespread.

Nonnative birds can cause big trouble for native species. Starlings and house sparrows, for example, compete with native cavity-nesting birds for nesting holes in trees and are a major reason that bluebirds have become rare in many areas. A large percentage of the birds in Hawaii have been introduced, with terrible consequences for some native species. Conservationists now oppose introductions of new species, fearing more unforeseen problems.

Mute swan. Often released in parks and on private lakes, these huge European birds can have a nasty temper. They are known to drive away—even kill—native waterfowl, and they occasionally attack people. Mute swans, which destroy aquatic vegetation, are becoming common in the East and the Great Lakes states. Conservationists are trying to control their numbers.

Ring-necked pheasant. Originally from Asia, the ring-necked pheasant was introduced to Europe. As early as the 1700s, European colonists were releasing them in America. These attempts were unsuccessful until the 1880s in Oregon. Pheasants are now common in farmland across much of the country and are a popular game bird. Other game birds that have been introduced include the chukar and gray partridges.

European starling. In the 1800s, many “acclimatization societies” sprang up in the United States, dedicated to introducing European birds to North America. One society in New York released the European starling, for no better reason than because it is mentioned in one of William Shakespeare's plays. It was a disastrous decision. Starlings are now found everywhere in North America except the Arctic. They compete with cavity-nesting birds such as flickers, bluebirds, and purple martins, contributing to their decline.

House sparrow. In an attempt to control insects that damage crops, people released house sparrows from Europe in many parts of the United States between 1850 and 1900. Instead of controlling insect pests, these small, drab birds made life difficult for native cavity-nesting species. Like starlings, they do best around humans and are not found in deep forest or wilderness areas. A close relative, the Eurasian tree sparrow, was introduced in 1870; because of competition with house sparrows, this species has remained in a fairly small area around St. Louis, Missouri, where it was first released.

House finch. These birds are native to the western United States and Mexico. In the 1940s, pet stores in New York illegally sold them as “Hollywood finches.” According to one story, when federal agents tried to intercept a shipment at an airport, smugglers released the birds. However they were first introduced, house finches rapidly spread across the East, South, and Midwest; today the species is found throughout the country.

Parrots. Escaped parrots, parakeets, cockatiels, and even macaws now thrive in many urban areas, particularly southern Florida, southern Texas, and southern California. Monk parakeets, potentially destructive agricultural pests from Argentina, survive winters in the Northeast and upper Midwest by roosting in huge, communal nests.

Cattle egret. This small, stocky white heron gets its name from its habit of following livestock, feeding on the insects they stir up. Its introduction was unusual because the bird came to North America on its own, instead of with human help. Cattle egrets are native to Africa, but they managed to cross the Atlantic to South America by the 1880s. They were first seen in Florida in 1941 and began nesting there in 1953. Since then, they have expanded over most of the United States and have even reached southern Alaska. Some birders now consider them essentially native.



What Makes a Bird a Bird?

Feathers are a bird's defining characteristic. No other living creature has them, although recent fossil discoveries show that some dinosaurs were also feathered. Feathers, which are related to the hair found on mammals, are extremely specialized structures. Feathers are among the most remarkable components in nature—light, tough, flexible, and colorful. Feathers provide insulation and waterproofing. And, of course, they permit birds to fly.

Feather Types

Feathers come in many different sizes and shapes, depending on their purpose. *Flight feathers*, found on the wings and tail, are long and stiff to provide lift for flight. *Contour feathers* cover the body like shingles, giving the bird a sleek shape and enhancing smooth air flow (minimizing wind resistance). Beneath the contour feathers are the soft and fluffy *down feathers*, which trap heat and keep the bird warm. Scattered over the bird's body, mixed in with the flight and contour feathers, are slender

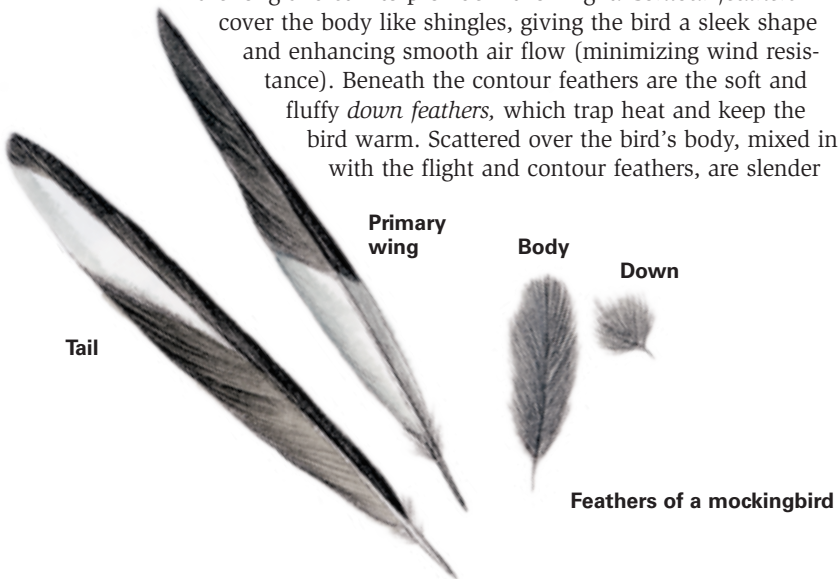

bristles known as *filoplumes*, which are attached to nerve bundles under the skin. Scientists think that filoplumes help the bird control the movements of the rest of its feathers. Taken together, all of a bird's feathers are known as its *plumage*.

Look at a feather under a magnifying glass. You will see that it has many thin strands, called *barbs*. After pulling them gently apart, you can use your finger to smooth them together again because each barb is covered with microscopic hooks, or *barbules*, that act like tiny zippers. Several times a day, a bird grooms its plumage with its beak in an act called *preening*, to neatly rearrange any messed-up feathers.

Like human hair, feathers grow from follicles in the skin. Each feather is replaced every year or so. The growing feather is encased in a sheath like a soda straw, which is full of blood to nourish the new feather. Once the feather reaches full size in several weeks, the blood is cut off, the sheath splits and is pulled away, and the new plume emerges.

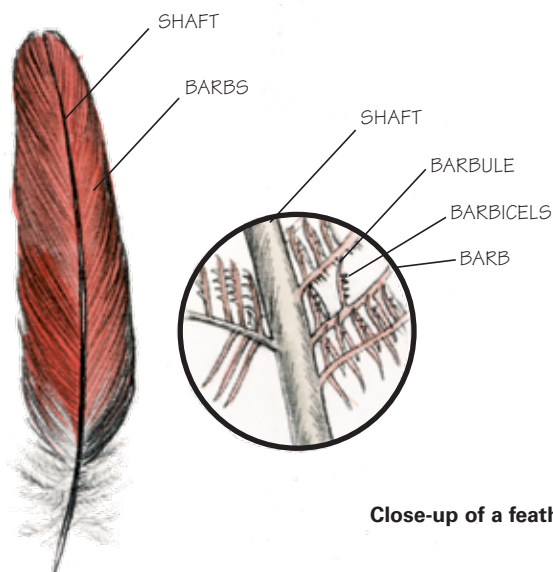

Tip: Your binoculars can double as a handy magnifying glass. Reverse them and look through one side of the “wrong” end. Move the binoculars close to the object you want to see—a feather, perhaps—and it will be magnified many times.

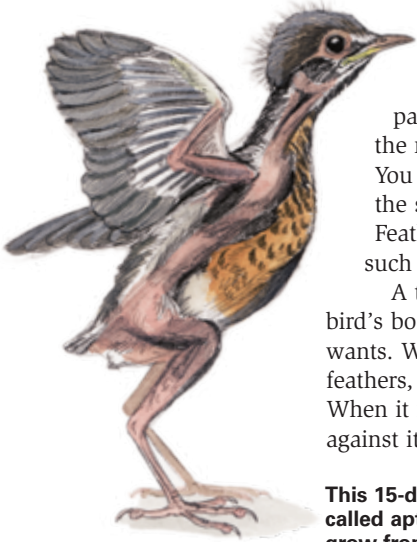

Feathers are not distributed randomly on a bird's body. Instead, they grow in areas called *feather tracts*, which cover certain parts of the body but leave bare other areas, like the middle of the belly and the sides of the neck. You usually do not see these bare patches, because the surrounding feathers overlap and cover them. Feather tracts are noticeable when a bird is wet, such as when it is bathing.

A tiny set of muscles controls each feather on a bird's body, so a bird can raise or lower its feathers as it wants. Watch a wild bird on a cold day—see it fluff its feathers, trapping more air between them for warmth. When it is ready to fly, the bird will flatten its feathers against its body so it is more streamlined.

This 15-day-old American robin shows areas of bare skin, called apteria, that will be covered by feathers as they grow from the feather tracts (pterylae).

How Many Feathers?

The number of feathers a bird has depends on its size. While bigger birds obviously have room for more feathers, birds also grow more feathers in winter, for insulation, than in summer. Scientists have carefully plucked and counted the feathers on dead specimens and found that most songbirds have between 2,000 and 2,600 feathers. Tiny hummingbirds have fewer than 1,000 feathers, while large swans may have more than 25,000, tightly packed to keep the bird warm and dry while it swims in cold water.

Parts of a Bird

Birders and ornithologists use special terms to describe the various parts of a bird's body and its different kinds of flight feathers, as shown in these illustrations.

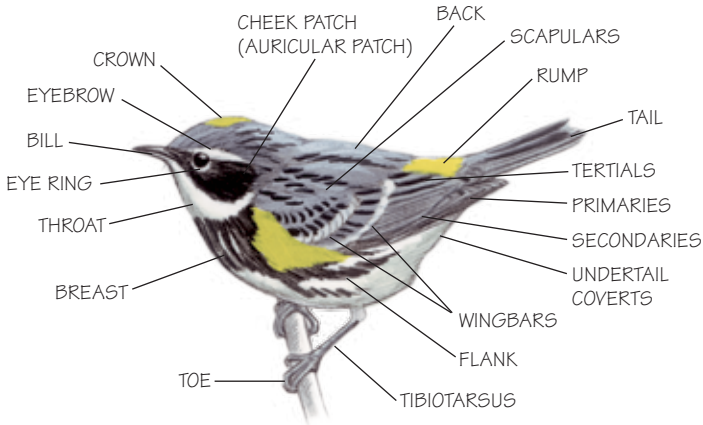

Parts of a yellow-rumped warbler

On a wing, the feathers are arranged in layers, with the largest, stiffest feathers—the flight feathers—near the tip and rear of the wing. The outermost flight feathers are known as *primaries*. The feathers from the bend of the wing to the body are called *secondaries*. A group of smaller flight feathers—*tertials*—lie where the wing and body meet. Just in front of the flight feathers is a row of smaller feathers, the *primary and secondary coverts*. Arranged like shingles in front of them are the *lesser coverts*. At the bend of the wing, the *alula*, or *false primary*, acts as a trim tab, keeping the bird trim (balanced) in flight, much as a pilot uses trim tabs to keep an airplane balanced.

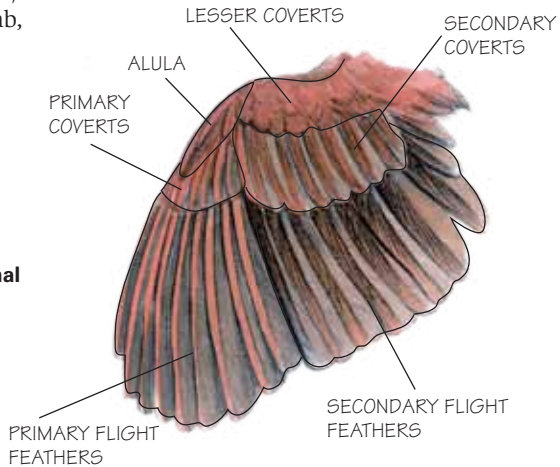

Wing of a northern cardinal

Bird Adaptations

Like its feathers, almost everything about a bird is designed to help it fly. Most birds have thin, hollow bones to save on weight. Instead of a mouthful of heavy teeth, a bird has a light-weight beak made of the same material as your fingernails.

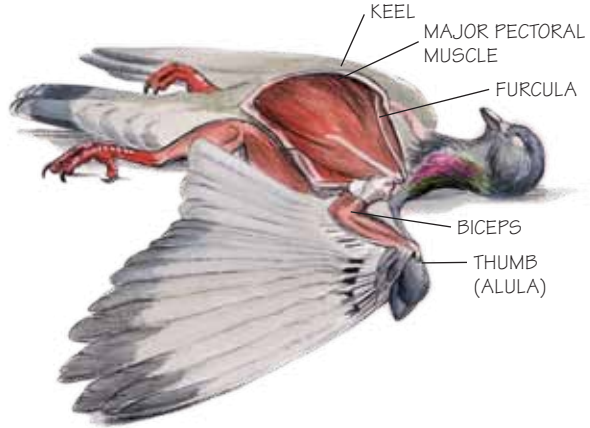

Rock pigeon

Most of a bird's chest is taken up by enormous flight muscles that are anchored to a breastbone, or *keel*. The wishbone, or *furcula*, lies in front of the chest, linking the two wings and the breastbone. It acts like a spring, adding force to each wingbeat.

A bird's legs might seem backward when compared to your own. A bird's knee bends to the rear, not to the front like a human's. But that is because a bird's "knee" is really its ankle, and what we call its "foot" are really its toes. Look at the illustration to see how a bird's leg works.

Perching mechanism of a pigeon. When the leg bends, tendons running to the toes are pulled shorter, causing toes to lock around a perch, which prevents a sleeping bird from falling off its perch.



Most birds share the same general adaptations for flight, but each species has its own unique adaptations for the specialized life it leads. Soaring birds, such as vultures, cranes, and hawks, have wide wings, for example. Fast species, such as swifts and falcons, have long, pointed wings.

Beaks are especially good examples of specialized adaptation. A red-tailed hawk's beak is hooked and sharp for tearing meat. A duck, such as a pintail or shoveler, has a wide, flat bill that is lined along the inner edge with tiny, comblike teeth for filtering seeds and minute animals from the water. Woodpeckers have chisel-like bills for hammering through wood for bugs, which they spear with their long, barbed tongues. Long-billed curlews have thin, curved beaks for plucking insects from deep underground.

Bills, from top: northern cardinal, American woodcock, hairy woodpecker, peregrine falcon, prairie warbler, great blue heron, mallard



ANVIL—
CARDINAL



FORCEPS/PROBE—
WOODCOCK



CHISEL—
WOODPECKER



SCISSORS/KNIFE—
FALCON



TWEEZERS—
WARBLER



SPEAR—
HERON



SIEVE—
DUCK



WADING—
NIGHT-HERON



PERCHING—
GROSBEAK



SWIMMING—
DUCK



TREE-CLINGING—
WOODPECKER



GRASPING—
HAWK



WALKING
(SNOWSHOE)—
RUFFED GROUSE

A hummingbird's needlelike beak is perfect for slipping deep into a flower so the bird can lap up nectar. Seedeaters, such as cardinals, sparrows, and grosbeaks, have thick, crushing beaks for cracking heavy shells. Common nighthawks have tiny bills but huge mouths that open like funnels to catch flying insects. The pelican's famous bill has a flexible pouch of skin between the beak and neck for catching fish.

There is plenty of variation in birds' feet and legs. Most songbirds have slender feet with short, curved nails for grasping twigs. A hummingbird's feet are so small that it cannot walk, only perch. To move even a little, a hummingbird must take off and land again.

Raptors, such as hawks and owls, have strong feet with long, sharp claws called *talons*, which they use to catch and kill their food. Woodpecker claws are strong and sharp, too, so the bird can cling to the side of a tree, using its tail as a brace.

Feet, from top: yellow-crowned night-heron, evening grosbeak, mallard, downy woodpecker, sharp-shinned hawk, ruffed grouse

Wading birds, such as herons, egrets, storks, and rails, have long, thin legs so they can move through shallow water without getting their feathers wet. Ducks, geese, and swans have webbed feet for swimming, while grebes have folding flaps along the sides of their toes that accomplish the same thing.

Some birds have more unusual adaptations. Vultures have bare heads because feathers would become fouled and matted when the birds fed inside a carcass. All birds have ears—holes on the sides of their heads beneath the feathers—but some owls have one ear hole that points slightly up and another that points slightly down. This helps them to locate small animals when it is almost too dark to see.



The black-crested titmouse inhabits parts of central Texas.

The tufts of feathers on top of some owls' heads break up the silhouette, thus helping to camouflage the owl, and have nothing to do with hearing.



Great horned owl, left, showing field of binocular vision; American woodcock, right, showing wide field of monocular vision, reduced field of binocular vision

Birds have excellent vision. Unlike most mammals, they can see color very well. Hawks, eagles, owls, and other predatory birds have binocular vision—eyes that face forward, so both eyes can focus on an object at the same time. This makes it easier for the bird to judge how far away something is. (You can see this for yourself by holding a hand over one eye while you reach for an object.) Most other birds have monocular vision—eyes placed on the sides of the head so they can watch a wider area for danger.

The American woodcock, a shorebird that lives in damp woods, has eyes so far back that it actually sees slightly better behind it than in front.

Bird Origins

Many characteristics of birds are similar to those of reptiles. Both lay eggs and have scales on the legs and feet. As early as the mid-1800s, scientists suspected that reptiles and birds were related. The proof came in the 1860s, when a spectacular fossil known as *Archaeopteryx* (meaning “ancient wing”) was found in Germany.

Archaeopteryx, which scientists speculate lived millions of years ago, had many reptilian features, including teeth, clawed fingers, and a long, bony tail. As the fine-grained rock in which it was fossilized clearly showed, it also had wings and tail feathers, as well as many bones that were similar in shape to a bird’s. Over the years, six other *Archaeopteryx* fossils have been found.

One of the biggest remaining mysteries about bird evolution is whether birds came directly from dinosaurs or from a more ancient kind of reptile that was also the ancestor of dinosaurs. For many years, ornithologists thought birds descended from small dinosaur ancestors that lived in trees and developed feathers to help them glide. But in recent years, *paleontologists* (scientists who study extinct animals) have uncovered several kinds of ground-dwelling dinosaurs that are similar in body shape to *Archaeopteryx*, including the fast predator *Velociraptor*. They have also found the fossils of dinosaurs in China that clearly had wing and tail feathers. Now, most scientists have concluded that birds evolved from ground-dwelling dinosaurs that developed feathers for insulation, and only later took to the air.

***Archaeopteryx*
in cycad swamp
(Jurassic period)**



How Birds Live

From bugs to fish, seeds to mice, and fruit to carrion, it is hard to find a food that some kind of bird does not eat. What a bird eats, and how it obtains its food, has much to do with its physical adaptations, like the shape of its bill and feet, as well as the kind of habitat in which you are likely to find it.

Food and Feeding

Most birds eat a variety of certain kinds of foods—mostly insects, for example, or mostly seeds. Many songbirds switch from an insect diet in summer to one that includes fruit, berries, seeds, or nuts in autumn and winter when cold weather drives insects into hibernation. Others stick to bugs year-round, prying them out of their winter hiding places or even old spiderwebs.

Some birds have highly specialized diets. The most extreme example may be the snail kite, an endangered hawk that, in the United States, is found only in the Everglades of south Florida. The snail kite feeds only on the large apple snail, which it plucks from shallow, weedy marshes; carries to a perch; and pries open with its unusually thin, curved bill. The ground beneath a kite's favorite perch is often littered with dozens of empty snail shells.

People who are finicky about their food or do not eat much are often said to “eat like a bird.” Nothing could be further from the truth. A bird's body operates at high gear and requires great amounts of food—at least in comparison to the size of its body. Some warblers eat more than three-quarters their weight in insects every day. That is the same as a 100-pound boy eating 75 pounds of food! The ratio drops in larger birds, but even a brown pelican eats half its weight in fish daily, and a golden eagle eats 15 percent of its weight in meat.

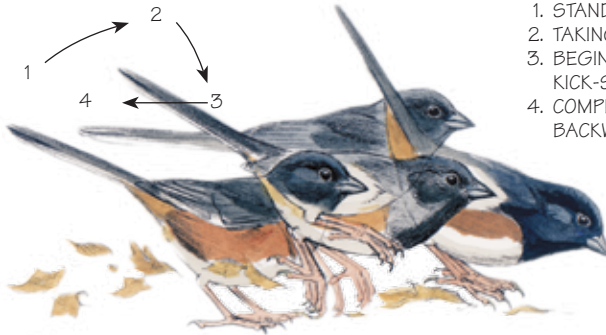

1. STANDING.
2. TAKING FORWARD HOP.
3. BEGINNING BACKWARD KICK-SCRATCH.
4. COMPLETING BACKWARD KICK.

Feeding behavior—eastern towhee

Every kind of bird has its own unique approach to finding food. There can be great differences in technique, even among closely related species. Watch a group of shorebirds along the beach, and you can see this for yourself. Sanderlings chase the waves in and out, picking up tiny animals tumbling in the water. Ruddy turnstones use their short, stubby bills to patiently flip bits of shell and seaweed above the high-tide line, looking for invertebrates underneath. Oystercatchers use their thin, knife-shaped bills to pry apart mussels and other shellfish. Phalaropes (small shorebirds the size of sparrows) spin in tight, fast circles while swimming, creating miniature whirlpools that concentrate food near the surface.

Clockwise from top left:
American oystercatcher
 prying mussel open;
Wilson's phalarope
 spinning on water's
 surface; **ruddy turnstone**
 flipping rock; **sanderling**
 probing in wet sand



Some birds join forces to catch their food. As a group, white pelicans may swim in a huge circle in shallow water, corralling fish where they can easily be caught. Harris' hawks in the Southwest hunt in packs and share the jackrabbits that they kill. In the past, gulls dropped clams on rocks to break open their shells. Now gulls use roads for the same purpose, and also benefit from cars that run over and break the clams open.

The most unusual hunting technique may be bait fishing. Green herons in the United States, and closely related species elsewhere in the world, drop bits of food, flower petals, or other small objects on the water and then nab fish that come to investigate.



Some birds store food when it is abundant to get them through leaner times. In late summer, the Clark's nutcracker of the western mountains gathers tens of thousands of seeds from coniferous trees, stashing the seeds in the ground in as many as a thousand different places. This bird's remarkable memory allows it to remember where each cache is, even months later. Acorn woodpeckers, which live in family groups of up to 16 birds, drill holes in dead trees (and often telephone poles) and hammer acorns into them. A single tree might have as many as 50,000 embedded acorns.

In other parts of the world, the Egyptian vulture drops rocks on eggs to break open a feast. The Galapagos woodpecker finch uses thorns or twigs to pull insects from rotting wood.

Behavior Tip

If you have a bird feeder, watch to see whether any of the birds coming for your seed are storing food. Jays, chickadees, titmice, and nuthatches often *cache*, or store, food by tucking seeds behind flakes of bark, among the needles of pine trees, or between cracks in the walls of buildings. Although harder to observe, hawks and owls often do the same thing with excess prey.

Courtship and Nesting

Before a bird can breed, it must first establish a *territory*—a piece of its habitat that will supply all the things it, its mate, and its chicks will need, such as food, *cover*, water, and safety. Generally it is the male that claims a territory, singing and displaying both to warn away rivals and to attract a mate. Territories may be small (those of some songbirds are less than an acre) or huge. Golden eagles sometimes have territories that cover hundreds of square miles.

Birds have many strategies for attracting mates, but they usually come down to one thing—advertisement. Each species has its own advertising style. Males may dance, soar, sing, croak, drum, or run across the water to try to catch a female’s attention. Birds’ courtship rituals, like the evening flights of male woodcocks, are often amazing to watch. These little shorebirds gather in weedy fields and open woods at dusk, making froglike *peent* calls for several minutes before taking off. Each male flies in a rising circle, his wings making a whistling noise, until he is almost out of sight in the dark sky. Then he stops flying and begins tumbling to the ground, gurgling as he drops. At the last moment, he swoops down for a landing and starts over again.

Many North American birds engage in some sort of courtship dance. Sandhill and whooping cranes leap and spin in the air together, almost like human dancers. Male prairie-chickens and sharp-tailed grouse gather in groups to dance and patter, their heads lowered and brightly colored air sacs inflated on their necks.

Cover is natural shelter or protection.



Prairie warbler



Sandhill cranes dancing

Other species do not dance but have specialized courtship actions. Many ducks bob or shake their heads, and shake their tails—a signal that human observers often miss but that is instantly apparent to a female duck. Music, however, is the most important tool for many courting birds, especially the large group known as songbirds. Each species has its own characteristic song, but individual males may have slight variations that allow their mates and neighbors to recognize them. The song acts as both a “no trespassing” sign to other males and a “Here I am!” call to females. Males sing chiefly in spring and early summer, and less as the breeding season wanes.

Once a pair has formed, the birds must build a nest. In some species, only one sex (usually the female) builds the nest. In other species, including woodpeckers, both sexes work together. How long it takes to build the nest depends on its complexity. A mourning dove nest—a rickety collection of twigs and grass so thin that the eggs can be seen from below—may be finished in a day. An oriole’s deep, woven-bag nest may take the female two weeks to complete.

The female usually lays one egg per day. Most species wait until the whole *clutch*, or set of eggs, is laid before they start *incubating* (sitting on the eggs). That way, all the young birds hatch at about the same time. As with nest building, in some species only the female incubates; in others, males and females take turns. Among phalaropes, the female lays the eggs and then abandons them to the male, who incubates them and raises the chicks. (Female phalaropes are also the more colorful of the pair.)



Orchard orioles at nest in an apple tree

Most songbird eggs hatch about two weeks after they are laid. The babies are almost naked and completely blind. Their parents must protect them from cold, sun, and rain and feed them every few minutes.

Not all chicks are so helpless, or *altricial*. Baby waterfowl, shorebirds, and game birds (even chicks of the domestic chicken), among others, are *precocial*—meaning that they hatch with a thick coat of downy feathers and with their eyes open—able to follow their parents and feed themselves from birth.

Young birds grow quickly. Within 12 or 14 days, most songbird chicks are ready to leave the nest—even though they are not very good fliers. Known as *fledglings*, these youngsters spend several days flapping and crash-landing as they practice flying, while their parents continue to feed and watch over them. The family will stay together for a few more weeks, until the chicks have learned enough to care for themselves.



Precocial (piping plover, left) vs. altricial (eastern bluebird, right) chicks

Some birds build no nest at all. Peregrine falcons, nighthawks, and many shorebirds simply scrape a depression in the ground to hold the eggs.

To learn what to do if you find a baby bird, turn to the end of the section called “Creating a Backyard Bird Sanctuary.”

Cowbird Con Artist

One North American bird lets someone else raise its chicks. The brown-headed cowbird is a *nest parasite*, laying its eggs in the nests of other species and often throwing out the host’s eggs. The unsuspecting family raises the cowbird chick, which may quickly grow bigger than its foster parents. Some species recognize the intruder’s eggs and throw them out. The yellow warbler will build a whole new nest on top of the eggs, burying them inside.



Brown-headed cowbird egg, left, in a host nest of the black-capped vireo.

Bird Behavior

Crows, ravens, and jays, which are among the most intelligent birds, often learn new behavior through observation.

Part of the fun of birding is studying the behavior of birds. Much of a bird's behavior is *instinctive*, meaning the bird is born with the urge to behave in certain ways. Some behavior is *learned*, something that the individual bird discovered on its own or copied from others.

Described here are some common forms of bird behavior, which you might be able to observe for yourself in birds you see all the time.

Feeding

Stalking. A common tactic used by herons and egrets, stalking involves slowly creeping up on prey until the bird is close enough for a quick, stabbing strike.

Hawking. This hunting behavior is rarely performed by hawks, but rather by agile birds such as swifts, swallows, and nightjars that catch flying insects on the wing.

Pouncing. Many birds take a wait-and-see approach to hunting, sitting on a perch until something edible comes along, and then dropping down on it. Pouncing is common among hawks and owls, but some songbirds, including the bluebirds, also practice it.

Flycatching. A specialized way of catching insects, flycatching involves flying out from a perch, snapping up a passing bug, and then flitting back to the perch to wait for another. Flycatchers are good at this, naturally, but so are waxwings, warblers, and many other songbirds, as well as hummingbirds, which eat many small insects.

Probing. Birds with long bills often use them to poke for food in hidden places. Brown creepers use their curved beaks to check behind flakes of tree bark. Ibises probe into mud for crayfish.

Scratching. Many ground-dwelling birds scratch with their feet to uncover food. Turkeys and other game birds use one foot, whereas sparrows, towhees, and buntings kick back with both, making more noise in dead leaves than you might think a small bird could make.

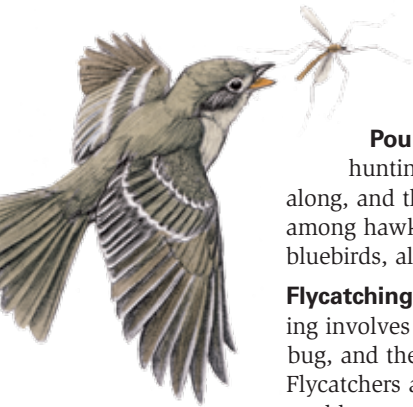

Dusky flycatcher chasing crane fly

Cleaning

Preening. Several times a day, a bird will carefully groom its feathers, nibbling at them with its bill to smooth and clean them. Birds also take oil from a tiny gland at the base of the tail and spread it over their feathers to help make them waterproof.

Bathing. Birds will bathe in shallow water when they can, splashing it over and through their feathers before preening. They will also “bathe” in dust, often along the edges of roads. Scientists think dust baths kill parasites that live in their feathers.

Stretching. Birds often stretch, opening first one wing, and then the other, fanning the same side of the tail as they do.

Anting. This strange behavior still puzzles scientists. Birds will sometimes rub ants into their feathers with their beaks or stand on a swarming anthill, allowing the insects to run through their feathers. It is thought that the ants may kill tiny parasites on the bird’s skin, or that chemicals the ants give off may drive away such pests.

Social Behavior

Flocking. The most obvious bird behavior is flocking—gathering in large groups to feed, sleep, or migrate. Birds gain safety by flocking because it is harder for a predator to approach the group without one of the birds seeing it and sounding the alarm.

Mobbing. The appearance of a predator like a hawk or cat will draw many smaller birds together to scold and dive at it. Mobs sometimes follow a predator for long periods of time, foiling its chances of surprising a meal. Mobbers themselves are sometimes mobbed. Crows will harass hawks and owls, but they are mobbed by smaller birds because crows eat their eggs and chicks.

Distraction displays. If you get too close to the nest of many species of birds, the mother may pretend to be injured, fluttering and calling to lure you away from her chicks or eggs.



Preening eastern bluebird

Birds sometimes “ant” with such objects as cigarette butts or mothballs.



Piping plover—distraction display at nest

Migration

Not all birds migrate. Species that remain in one area year-round, called *permanent residents*, include such common birds as chickadees, titmice, and downy woodpeckers. In other species, some individuals migrate while others remain behind.

Of all the amazing things about birds, *migration* is one of the most astounding. Flying on instinct—that is, with an inborn urge that is not learned or reasoned—a tiny warbler only a few months old, for instance, can leave the northern United States and travel without error to its ancestral wintering grounds in places like Central America or the Caribbean. Some small birds take shortcuts across the Gulf of Mexico and the western Atlantic Ocean to reach Mexico or South America. Many shorebirds fly from Alaska to the islands of the South Pacific, a journey of four or five days without rest, food, or water.

Scientists are beginning to understand how birds can navigate across such vast distances. Many birds migrate at night and can use the stars as a map. By day they track the sun's position in the sky. Most birds do not learn the way south and north from their parents. They sense Earth's magnetic field almost like a compass, and they learn and remember landmarks. Young birds usually travel alone or with others of their age, going strictly on instincts that tell them which way to fly. Scientists use many different methods to learn about bird

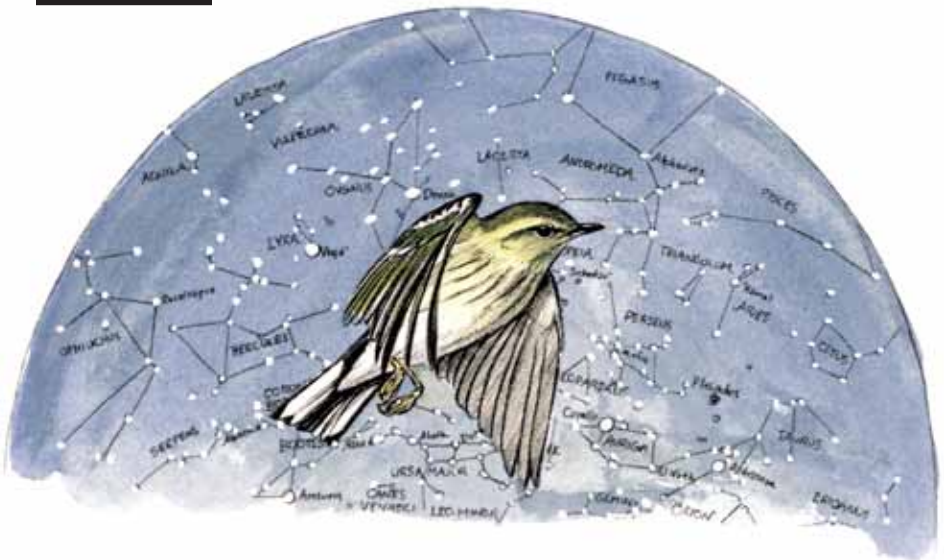

Birds that migrate don't usually do so in winter because it gets cold; birds can tolerate extremely cold weather, but their food is hard to find then. Most migrants eat insects, fruit, flower nectar, reptiles and amphibians, or other food that disappears when it gets cold. Waterbirds must migrate because lakes, ponds, and wetlands freeze.

migration. Among the most important is bird *banding*, in which a researcher places a light metal ring around a bird's leg. On the band is a series of numbers unique to that bird, and either an address or a telephone number for the federal Bird Banding Laboratory in Maryland. By reporting where and when they find banded birds, people across the country help scientists track birds' migration. Banding also tells us how long birds live and a great deal more about their lives.

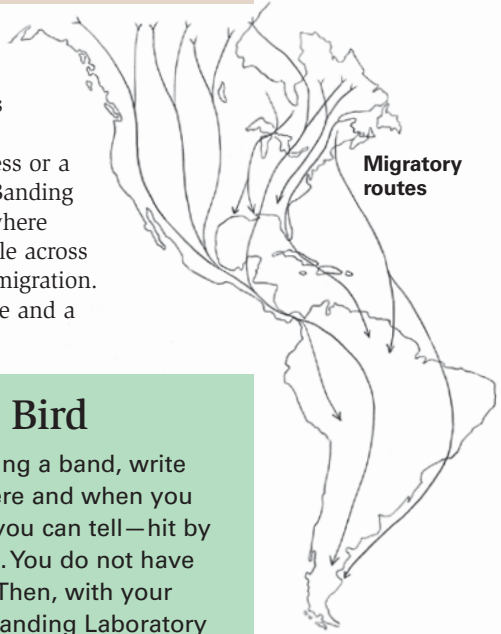

If You Find a Banded Bird

If you find a dead bird that is wearing a band, write down all the numbers, exactly where and when you found the bird, and how it died, if you can tell—hit by a car or killed by a cat, for instance. You do not have to remove the band from the bird. Then, with your parent's permission, call the Bird Banding Laboratory toll-free at 800-327-2263 and leave the information, with your name and address. You will receive a certificate of appreciation telling you where, when, and by whom the bird was originally banded.

(Do not report banded pigeons to the Bird Banding Laboratory. People who raise pigeons for racing or for show place bands on them, and the lab does not track these pigeons.)





Migration doesn't always take a bird to warm, tropical places. Rough-legged hawks, which nest in the Arctic, migrate south each winter. They make their destination the cold, snowy prairies of the West and Great Plains, or open farmlands in the Midwest and Northeast.



Bar-tailed godwits, dove-sized shorebirds that nest in western Alaska, migrate nearly 7,000 miles nonstop across the widest part of the Pacific Ocean to their wintering grounds in New Zealand and Australia. Before they begin the trip, they eat so much that they double their weight. Then their digestive tract shrinks in size, even as their heart and flight muscles expand to give them extra stamina. Once they arrive in the south, the changes reverse themselves.

Unlike many birds that live in the mountains of the West and that move to lower, milder elevations in the winter, blue grouse actually migrate high into the mountains. These hearty birds travel *on foot* and feed on the buds of conifer trees until spring arrives.



Eastern kingbirds, which during the breeding season feed exclusively on insects, switch diets once they migrate to South America. Once there, these handsome birds—which are agile and bold enough to catch bees and hornets—form huge flocks and feed on little except tropical fruit.



Observing Birds

You do not need much equipment to go birding. Binoculars, a field notebook, a field guide, and a pencil will get you started.

Binoculars

The single most important piece of gear for any birder is a good pair of binoculars (also referred to as field glasses, or just “binocs” or “bins”). Binoculars bridge the distance between you and a skittish wild bird, allowing you to see the details that help you to identify it while you avoid disturbing the bird. They also open up a world of fascinating behavior that you might otherwise miss.

Choosing the right binoculars takes a little homework and some thinking about the kind of birding you will be doing most often. Some styles are better for watching songbirds in the woods, where you will need to focus on nearby objects. Others are best for watching distant hawks or shorebirds, where greater magnification is needed.

Choosing binoculars is also a balancing act between what you want and what you can afford.

Extremely cheap models may frustrate you during birding because the fuzzy, misaligned images they produce make it difficult to see the bird clearly. On the other hand, some top-of-the-line binoculars that are armor-coated and waterproof cost more than \$1,000. The secret is finding a good, relatively inexpensive model that meets your birding needs.



What Do the Numbers Mean?

Every pair of binoculars has a set of numbered specifications on it, like 7X35, 8X40, or 10X50. The first number refers to the *magnification*—how large the binoculars make an object appear when you look through them. The larger the number, the greater the magnification. But as the magnification increases, the *field of view*—the area you see when you actually look through the binocs—gets smaller. A small field of view makes it harder to find a bird in the glasses.

Higher magnification also increases the *minimum focusing distance*—how close to you the binoculars can be focused. That means that while a pair of 10-power binoculars make a bird look larger than a 7-power pair will, you might not be able to focus on it if the bird is fairly close to you, say, 15 feet away—a common distance when watching songbirds. It is frustrating to have to back up to watch a bird, but it will happen if your binoculars are too powerful.

The second number of the specification shows, in millimeters, the width of the large objective lenses at the front of the binoculars. The larger the number (and the lens), the more light the binoculars take in and the brighter the image you see. Most birding experts recommend 7X35 binoculars as the best choice for beginners, combining reasonable magnification with sufficient field of view, although 8X40 is also a good choice.

Generally speaking, avoid binoculars with less than 7X magnification. Avoid compact binoculars with an objective lens size of less than 35mm—the field of view is so small it can be frustrating to find the bird, and the image tends to be dark and murky. Ten-power binoculars are often used by birders who specialize in watching hawks, shorebirds, and waterfowl, but these are more expensive and can be tough to hold steadily. Do not use binoculars greater than 10X, such as maritime glasses; they are too heavy and bulky for birding.



Choosing Binoculars

Roof prism binocs tend to be more rugged but also more expensive.

There are two main styles of binoculars—*Porro prism* and *roof prism*. The more common Porro prism style has objective lenses set farther apart than the ocular lenses that you look through. Roof prism binocs, which have all the glass elements lined up inside the lens barrel, look like two straight tubes joined in the middle.

Whenever possible, try binoculars before buying them. Make sure they feel comfortable in your hands and around your neck. If they are too big, you will have trouble holding them steadily. If they are too heavy, your neck and arms will ache after several hours of birding.

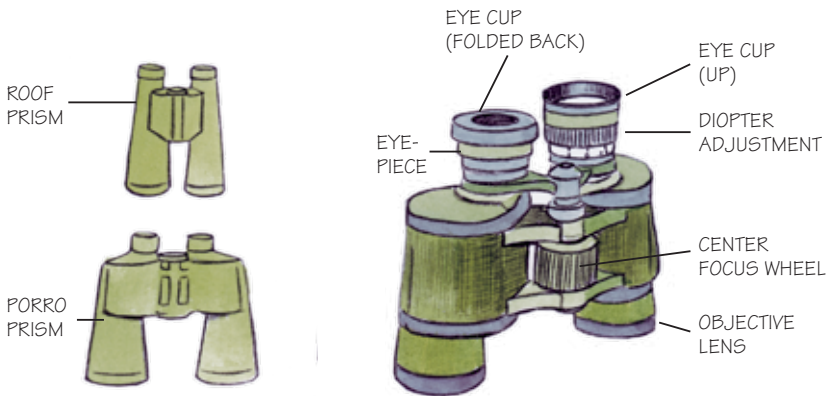

Binoculars

All good binoculars have a hinge in the middle, so you can push the sides closer together or pull them apart to match the distance between your eyes. When you look through them, you should see a single, circular image. The binoculars should also have a single focus knob or lever in the middle. Avoid models that require you to focus the eyepieces individually. If you wear eyeglasses, be sure you can roll down the rubber cups around the ocular lenses, a trick that increases the field of view.

Some binoculars come with *zoom magnification*—the ability to change from, say, 7 to 10 power by turning a dial or pushing a lever. Zoom mechanisms, which contain more elements than fixed-magnification eyepieces, are often fragile. Because you will be using your binoculars a lot, you will want a pair that is rugged. For this reason, most experts say, avoid zoom lenses.

Look through the binoculars, adjusting them to fit your eyes (the salesperson will help). A good pair will have a bright image, with no blurring around the edges or bands of color surrounding bright objects. Turn the binoculars over and look at the objective lens; when the light hits it at an angle, it should reflect a color like green or purple, a sign that the lenses are coated for maximum light transmission. Check to see how close the binoculars will focus (15 feet is a good distance), and make sure you can spin the focus knob easily while using them.

If possible, go outside and look at an object roughly a block away. If the image jumps and jiggles, the binoculars may be too heavy or too powerful; try a pair with lower magnification. Pick a brick or stone wall—something wide enough to fill the whole field of view—with a noticeable pattern and make sure that the image is crisp and clear from edge to edge, with no blurring.



Using Binoculars

Most binoculars come with a thin neck strap that is uncomfortable to use. If you can, replace it with a padded camera strap at least an inch wide. Or make your own strap from a piece of soft, 1½-inch-wide nylon webbing with metal split rings on each end. Whether you buy it or make it, the strap should be long enough to allow you to sling the binoculars over your head and one arm—a good way to carry them while hiking so they do not bounce.

Because each eye differs in its strength, you can adjust one of the ocular lenses (usually the right one) to match. This is known as the diopter adjustment. Here is how: Hold the binoculars to your eyes, but use one hand to cover the side with the adjustable lens. Then use the center focus knob to make the view through the other side clear. Take away your hand, and slowly turn the ring around the adjustable lens until there is no more blurriness and your eyes feel comfortable, with no strain. Once you have adjusted the eyepiece, you will do all your focusing with the center focus knob.

Learning to use binoculars well, especially finding birds quickly and easily, takes time. The trick is to raise the glasses smoothly without taking your eyes off the bird. It also helps to notice a landmark close to the bird, such as a clump of leaves or the shape of the branch the bird is perching on, so you can find it again in the binoculars. Practice when you are not birding by picking out objects and finding them in the binoculars. That way, when you spot an exciting bird in the field, you will not waste precious seconds trying to locate it in your glasses.

Caring for Binoculars

Unfortunately, it is easy to ruin a pair of binoculars. With proper care, a pair will last many years. One of the most important rules is to avoid bumping or banging your binocs against hard objects, which could jar the glass lenses and prisms out of alignment. If this happens, you will see two overlapping images instead of one. Using misaligned binoculars may give you headaches and strain your eyes.

Keep your binoculars dry. Water seeping into them can fog the inside of the lenses and leave them useless. If it starts raining, put them inside a waterproof bag or carry them beneath your raincoat or poncho.



Do not drop cleaning fluid directly on the lenses. It can seep inside and ruin the binoculars.



When you are not using them, keep your binoculars in their case. Clean the lenses regularly to remove dust and dirt. Do not use your shirttail or handkerchief or a paper towel to clean the lenses, which are easily scratched. Instead, get lens cleaning fluid and special lens cleaning paper at a camera supply store. Blow sharply on the lenses to dislodge dust and grit, and then brush them lightly with dry lens cleaning paper. Finally, crumple a piece of lens paper and put a few drops of cleaning fluid on it. Use a circular motion to gently clean the lenses.



Spotting Scopes

For birds that are too far away even for binoculars, birders often use *spotting scopes*—essentially low-power telescopes mounted on tripods or wooden gunstocks. Most scopes have zoom eyepieces ranging from 15 to 60 power, although the high magnifications are usually too dark and fuzzy to be of much use. Scopes are generally much more expensive than binoculars, but there are times when you may need a scope to identify a distant bird. Scopes should be used with a sturdy, lightweight tripod.

Spotting scope

Field Guides

An indispensable piece of birding equipment, along with binoculars, is a good field guide. This handy reference book allows you to quickly identify birds you may never have seen before.

In recent years, the number of field guides has exploded.

There are guides covering the entire continent or just parts of it; guides to particular groups of birds, such as hawks or warblers; guides illustrated with photographs or paintings; and guides designed for beginners or expert birders. You will find several excellent field guides listed in the resources section at the back of this pamphlet.



Generally speaking, you will do best to pick a guide that covers the entire country, especially if you live in the Midwest or Great Plains, where eastern and western birds mix. Although it is more confusing in the beginning, pick one that illustrates all the birds, not just the common species. Otherwise, you will eventually find yourself unable to identify some of the birds you see.

Traditionally, most birders preferred guides illustrated with drawings and paintings instead of photographs, because the artist can show exactly the colors and characteristics, known as *field marks*, that allow you to identify a new species. But there are new guides that use digitally enhanced photos, which do a much better job of showing how a bird looks in the field.

Be sure the field guide you pick has *range maps*, which show where the bird is found. This is an important clue as you try to figure out what kind of bird you are watching. Range maps use different colors to indicate the bird's breeding range in summer and its winter range, and yet another color if the bird stays in the same area year-round. Some guides also show the areas where the bird is found during migration.

A good field guide will show the different plumages of each bird, because the males, females, and immature individuals of many species wear different colors and patterns. Some species also change their appearance from season to season. There will be a short description of the bird, and a list of field marks that set it apart from all other species; this is usually where the songs and calls are described. When you are trying to identify a bird, these written descriptions are just as helpful as the pictures, so be sure to read them.

Many beginning birders are puzzled and confused by the order in which the birds are listed. Most field guides arrange the birds by taxonomic order, putting those that are closely related together, as explained in "Using a Checklist" at the end of this section. (One time-saving trick is to make tiny labels for each group—loons, ducks and geese, hawks, woodpeckers, and so forth—and attach them to the edges of the field-guide pages with folds of transparent tape. That way, to find a bird, all you have to do is thumb to the correct group tab.)

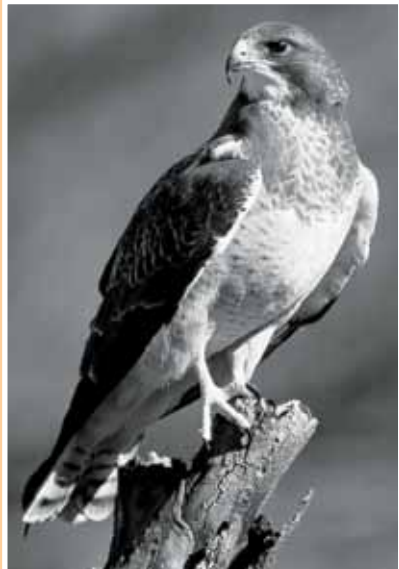

Swainson's hawk

A field guide will describe a bird's field marks and ranges, which will give you clues to identify it in the wild.

How to Identify Birds

When you see a new bird, you will be tempted to grab your field guide immediately and start paging through it, trying to find a picture that matches what you see. Don't. The best thing to do is study the bird a while, carefully looking for field marks.

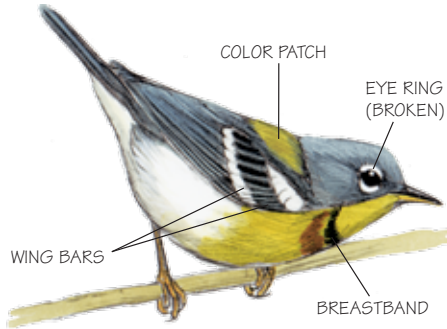

Northern parula, showing field marks—broken eye ring, wing bars, breastband (faint or absent in females), color patch

What is a field mark? Anything unusual or distinctive about the bird—its color, the pattern of its feathers, eye-catching markings, even the way it moves or flies. Some field marks are unmistakable, like the white head and tail of an adult bald eagle, or the red body and crest of a male northern cardinal. Others are more subtle. Shorebirds and fall warblers are notorious for having similar field marks that make it hard to tell one from the other.

Common Field Marks

Wing bars are the bands (usually white or a pale color) across the upper part of the folded wing.

Eye rings are thin circles of pale feathers or colored skin around each eye, common on many types of birds. Rings can be heavy and wide, like a pair of spectacles, or broken into two halves.

Crests are upright tufts of feathers on the heads of birds such as cardinals, titmice, and waxwings. Some owls have two feather tufts that look like ears.

Flash marks are areas of color, usually on the wings or tail, that are normally hidden but are visible in flight or during displays by the bird. The northern mockingbird has flash marks of white on its wings and tail that make this otherwise gray

The eastern phoebe and Say's phoebe in the West both pump their tails up and down when perched, a great behavioral field mark.

bird easy to identify from a distance. Juncos have white flash marks on the sides of their tails.

A bird doesn't really have a **mustache**—that's just the nickname for dark markings that extend back from the base of the bill.

Rump patches are white or colorful feathers just above the tail, found on species such as northern flickers and yellow-rumped warblers.

Bird Shapes

One of the most important clues for bird identification is the overall shape of a bird's body. A wood thrush and a brown thrasher, for instance, are colored much the same—rusty brown on top, with a white breast spotted in black. But the thrush is plump, with a fairly short tail and a short beak. The thrasher is slender and slinky, with a long tail and a long, pointed beak.

Another important clue to a bird's identity is how it behaves. Turkey vultures and young bald eagles are both big and mostly black, making them easy to mix up. But the vulture holds its wings in a shallow V when it flies, and the eagle holds its wings flat.

Colors and Patterns

Obviously, colors can be an important clue to a bird's identity. But you must be careful—colors on a live bird don't always look the same as those in a photograph or painting. Hummingbirds have brilliant, metallic colors, but only if the sun hits them just right. Otherwise, they can look black. The same can happen with many dark blue birds, such as indigo buntings. You should also remember that as a bird's feathers get old and worn through the year, they often become less colorful. Do not expect every bird you find to exactly match its picture in your field guide.

Birdsongs and Bird Calls

It's often said that good birders actually see only a small percentage of the birds they identify. The rest, they recognize from songs and calls. Birds are amazingly vocal creatures. Virtually every species makes a distinctive song, call, squeak, buzz, chirp, or rattle.

Often it is the combination of field marks, rather than a single mark, that clinches an identification.

White-throated sparrow, singing



Not all birds sing lovely songs, of course, and not all of their noises are vocal. The ruffed grouse makes an extremely loud drumming noise with its wings. Mourning dove wings make a distinctive whistling flutter when the bird takes off. Woodpeckers drum on hollow tree branches, making a clatter like a machine gun as a way of attracting mates.

Of course, you can't learn all those calls immediately. Start by learning a dozen or two of the most common birdsongs in your area. You can do this by listening to one of the tapes or CDs recommended in the resources section and by keeping your eyes and ears open when you are outside.

When you hear a song you do not recognize, try to track down the singer. While you are listening to the song, try to remember how it sounds (this is where your field notebook is handy), perhaps by putting words to it—an old and effective trick that birders use. To many people, the song of the white-throated sparrow sounds like *Oh, SWEET Canada Canada Canada*, while the red-winged blackbird sings *Ok-a-LEEEE!* Common yellowthroats sing *Whichity-whichity-which*, and the yellow warbler sings a hurried *Sweet-sweet-sweet I'm so sweet*.

Taking Good Field Notes

“There is a third species of brant [goose] in the neighborhood of this place. A little distance around the base of the beak is white and is suddenly succeeded by a narrow line of dark brown. The balance of the head, back, wings and tail, all except the tips of the feathers, are of the bluish brown of the common wild goose. The breast and belly are white with an irregular mixture of black feathers which give that part a pied [blotched] appearance.”

Captain Meriwether Lewis wrote that excellent description of a greater white-fronted goose—one of the first ever seen by an American explorer—in 1806, when the Lewis and Clark expedition spent the winter by the Pacific Ocean in what is now Oregon. Even though they were crossing thousands of miles of unexplored country, Lewis and Clark often took time to write detailed notes about the wildlife they saw, including 11 species of birds that were entirely new to science. (Two of them, Lewis' woodpecker and Clark's nutcracker, were later named for the explorers.)

Field notes are an important tool for anyone who studies birds, from a casual birder to a serious ornithologist. Whether you are trying to identify a species you have not seen before, hoping to document a rare bird, or recording aspects of behavior, a notebook and pencil are as important as your binoculars and field guide.

Use a field notebook small enough to fit easily in a shirt pocket or outside compartment of a pack. Always carry several sharp pencils, with erasers. (Ballpoint pens won't write on wet paper, and markers smear in the rain and don't work in the cold.) A notebook with a waterproof cover helps, but also carry a heavy plastic bag in your pack, in case it rains.

There are many ways to organize a field notebook. You might decide to devote an entire page to one species of bird, noting its color, pattern, song, or behavior. Or, you might keep lists of all the species of birds you encounter on your field trips. Perhaps you will make a series of notes, over the course of several weeks, as you watch a nest, observing how the parents care for the eggs and chicks. No matter how you organize your notebook, be sure to include such basic information as the date and time, the weather, and the habitat in which you found the bird.

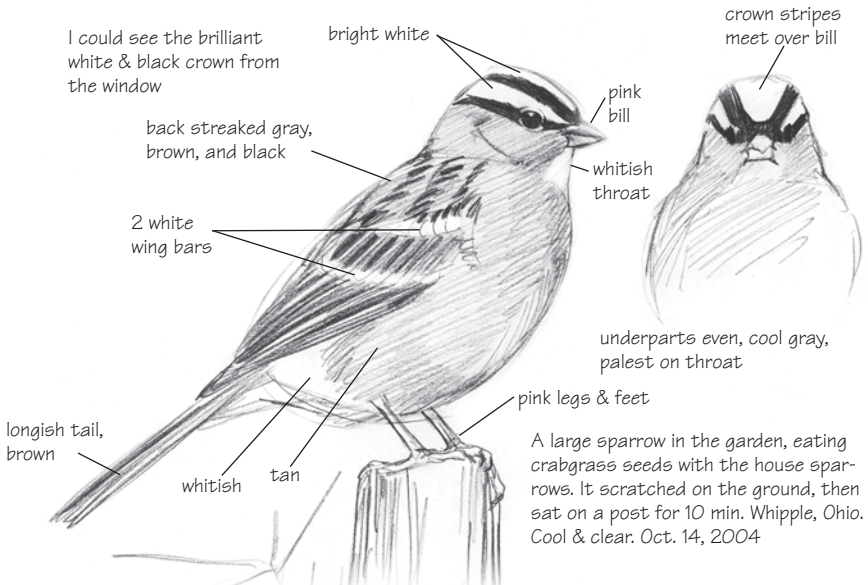

Field sketch for identification—white-crowned sparrow

Field Notes

Here's an example of field notes.

Ruby Lake National Wildlife Refuge, Nevada

July 19, 6:10–9:15 A.M.

Weather: Sunny, temp. at dawn 55°, rising to 80°. Light wind.

Birds seen while canoeing South Marsh:

Pied-billed grebe

Eared grebe

Double-crested cormorant

American bittern (one heard calling)

Great blue heron

Black-crowned night-heron

Cinnamon teal

Northern shoveler

Canvasback (female with chicks)

Lesser scaup

Turkey vulture

Northern harrier

American kestrel

*Sage grouse (6 on road leading to boat launch)

American coot (some still with very small chicks, other chicks almost grown)

Sandhill crane (one pair with fledgling)

Forster's tern

Caspian tern (3)

Black-billed magpie

Common raven

Marsh wren (many feeding fledged chicks)

Sage thrasher (on island)

Brewer's sparrow (on island)

Yellow-headed blackbird

*life bird

Comments: Coots were calling constantly, and we were able to drift very close to several of the youngsters. Saw an eared grebe surface with a fish that was almost too big for it to swallow, but somehow it managed. Sage grouse were the highlight of the trip!

Identification Notes

Here's an example of identification notes.

May 25, 10:17 A.M.

Moyer's Woods Sanctuary, along
upper path through oak forest

Bird smaller and slimmer than
chickadee, pale gray but a bit darker
on back and wings. Tail long and
narrow, with white feathers on outer
edges, and white underneath. Thin
white eye ring. Bill short and thin.
No wing bars. Very active—flycatches,
hovers while feeding. Stays high in
tree, giving high **pweeee** calls.

From these notes, it is easy to identify the mystery bird as a blue-gray gnatcatcher.

If you are lucky enough to spot a really unusual species, good field and identification notes will help confirm your find with those birders and ornithologists who keep the official records of bird sightings for your state or county.

Good notes can be a big help in identifying a new bird, or helping to document a rare species. Even if you have a field guide handy, it is a good idea to jot down quick notes about a bird you can't identify. That way, you won't have to rely on your memory later, when you try to find the bird in a guide. It is also a good idea to make a little drawing of the bird, showing the field marks you observed (you do not have to be a good artist to do this).



Greater white-fronted goose

Getting Close to Birds

Move slowly and quietly when you are birding, using your ears as well as your eyes. Cotton, wool, or pile jackets are better than nylon, which swishes and makes a lot of noise. If possible, keep the sun at your back instead of in your eyes. Train yourself to notice small movements, especially out of the corners of your eyes. Stop frequently to look and listen.

If you dress in dull-colored clothing, you will blend in with the surroundings and be less likely to scare away birds, which (like humans) have color vision.

Birders often use two tricks, squeaking and “pishing,” to lure shy songbirds out in the open. To squeak, purse your lips and kiss the back of your hand or the side of your fist; try to get a series of short, high-pitched squeaks like a mouse in distress. To “pish,” make a hissing, whispering sound with your lips—*pish-pish-pish-pish-pish*. No one is exactly sure why squeaking and pishing work, but they often attract curious songbirds. How successful you will be depends on the season and the bird. Both tricks work best during the breeding season, when birds are eager to defend their territories. And they work better on some birds, like chickadees and kinglets, while hardly at all on others.

While it is possible to use tape recordings of their songs to attract birds, conservationists frown on this practice. A tape lures a singing male away from his territory to chase what he thinks is an intruder, perhaps taking him away from caring for his chicks. Repeated use of tapes can actually drive birds away.

It is sometimes permissible to use tapes to locate owls, which are difficult to find otherwise.

If you use a tape to go “owling,” observe these rules: Do not use tapes during the courtship and nesting season (which extends from midwinter



A screech-owl, lured in by a recording of its call, arrives unnoticed by birders.

to early summer for most species). Regulations in many protected wildlife areas prohibit tapes. Do not use them at all in parks, refuges, and other heavily birded areas. Do not overuse them. Play a tape only for a short time, and stop once you get a response. For real fun, learn to imitate owl calls with your own voice instead of using a tape. It is possible to hold a conversation of sorts with a wild owl.

Birding Dos and Don'ts

Do

- Move slowly and quietly.
- Use your ears as much as your eyes.
- Respect private property. Always ask permission before birding on someone else's land.
- Stay on paths and trails when birding in parks and refuges.
- Look for birds early in the morning and late in the afternoon, when they are most active.



Don't

- Disturb birds any more than necessary, especially those that are courting or nesting.
- Approach or touch nests. You might scare away the parents or lead predators to it. Watch through binoculars from a distance.
- Collect feathers, eggs, or nests—it is against the law. (See the end of the section called "Creating a Backyard Bird Sanctuary" to learn what to do with dead or injured wild birds.)

It is considered a real accomplishment to have a life list of more than 600 or 700 species, out of the more than 800 found in North America. Achieving such a goal can take decades.

The Sport of Birding

Birding can be many things—a hobby, a form of science, or a sport, in competition with yourself or with others.

Keeping Lists

Almost all birders keep a life list—a tally of all the species of birds they have seen in their life, including the date and place where they saw each one. A life list can take you back to the moment when you saw a species new to you—a life bird—and help you to relive the excitement.

You can keep your life list in your field notebook. Or, you can record it in your field guide, either by jotting down the date and place on the page next to the bird, or by making tiny check marks next to each bird's name in the index. (Some guides provide small boxes for that purpose.) It's a good idea to keep two copies of your list, in case you lose your field guide or notebook. There are even a few commercially printed life list books available. Also, several brands of computer software are available that will track your life list for you.

Most birders keep a life list for their own pleasure. Others view it as a form of competition, trying to exceed other people or their own personal record. The American Birding Association has rules for its members about where and how they can count birds for their official ABA lists, and the competition leaders—those with the most species on their life lists—are recognized every year in ABA publications.

People keep “yard lists” of all the birds they have seen at their homes. Also popular are county lists, state lists, and trip lists. Sometimes they will tackle a “Big Day,” trying to see as many species as they can in 24 hours (often starting long before daybreak to find owls and other night birds), or a “Big Year,” hoping to find as many birds as possible within 12 months.

The ultimate in listing is the World Series of Birding, a version of the Big Day held every year in New Jersey. Teams from around the world (including some youth teams) compete to see how many species they can find in 24 hours. Teams often map out elaborate, precisely timed routes across the state to locate the maximum number of birds in



Not every birder keeps lists. Some think that by focusing on finding and listing lots of species, birders miss out on the fun of observing and studying the more common birds. Fortunately, there is no right or wrong about it. You can list or not, as you like.

the minimum amount of time. Many teams are sponsored by conservation organizations, which solicit pledges from their members—a certain amount of money per species—as a way to raise money. The winners of the World Series receive a trophy, but no cash prizes.

Using a Checklist

Many parks, national wildlife refuges, and nature sanctuaries provide small, printed checklists of the birds found on their property. This is a handy way of recording what you have seen and an excellent way to learn more about the kinds of birds found locally. Checklists are arranged in taxonomic order, just like most field guides. They will usually tell you what species breed there, what kinds of habitat they use, and their abundance in spring, summer, fall, and winter, using codes such as *C* for “common” and *R* for “rare.”



Joining a Bird Club

One of the best ways to learn more about birds and birding is to join a bird club or natural history society. Most communities have such organizations. Clubs usually offer regular evening meetings, and guided field trips to local birding hot spots where you will see new and exciting species. Besides sharpening your birding skills, participating in a club is a good way to meet other birders, to take part in activities like annual Big Days or Christmas Bird Counts, and to learn more about environmental issues of concern to birders.

Before going online, be sure you have your parent's permission.

Rare Bird Alerts

Birders often learn about unusual species of birds through rare bird alerts, known as RBAs or bird hotlines. Usually, an RBA is a recorded telephone message, updated regularly, listing many of the interesting sightings and rare birds seen in the past week or so, with directions. RBAs often also include details about local bird club meetings and field trips. Most RBAs are now posted on the Internet. The American Birding Association maintains a list of all rare bird alerts in the United States and Canada on its Web site; click on the RBA Reports icon.



Northern hawk owl

Bird Study and Science

As a birder, you can make valuable contributions to science, especially if you work with one of the many research programs—run by universities, conservation groups, and government agencies—that use volunteers. Some projects demand a high degree of experience, while others accept beginners by pairing them with more skilled birders.

Christmas Bird Count

Every winter, tens of thousands of birders head for the outdoors to conduct the annual Christmas Bird Count, coordinated by the National Audubon Society. Begun in 1900 by Massachusetts ornithologist Frank Chapman and a few friends, the CBC has grown into the largest and longest-running wildlife survey in the world. This event attracts more than 50,000 volunteers and provides conservationists with valuable information about bird populations.

Nearly 2,000 CBCs are held every year during the last two weeks of December and the first week of January. Most are in North America, but in recent years CBCs have begun in Central and South America and in parts of the Pacific. Each count covers a circle of land 15 miles wide, across which teams of birders try to count all the species and individual birds they find during a 24-hour period. They also record information on weather, snow cover, and how many hours each observer searched for birds. Some people also keep an eye on feeders, to record the birds seen there.

At the end of the day, everyone gets together to compile the results of the count, usually over a hot meal. Counts may range from only a few dozen species in Alaska to several hundred in places like Texas and California.

CBC results have been a bonanza for scientists because the count provides a detailed census of winter bird populations every year. The Christmas Bird Count has shown some species, like house finches, expanding their range, whereas others, like loggerhead shrikes, have become much scarcer in some regions.

Although the National Audubon Society coordinates the overall Christmas Bird Count, each local count may be run by a bird club, conservation organization, or just a group of interested birders. There is a small fee to take part. To find out about counts in your area, check with birders you know, ask at a nearby nature center, or write to the National Audubon Society. You can also find out more about the Christmas Bird Count online with BirdSource, a cooperative project of the National Audubon Society and the Cornell University Laboratory of Ornithology.

North American Migration Count

Every spring and fall, birders across North America record the migrating birds they see. The North American Migration Count is a warm-weather version of the Christmas Bird Count and is designed to provide a kind of snapshot of bird migration across the continent. Unlike the CBC, however, the NAMC covers entire counties, and participation is free. For more information on local counts, write to the NAMC coordinator.

Project FeederWatch and the Great Backyard Bird Count

Project FeederWatch enlists people all around North America to watch their bird feeders, recording the species and numbers of individual birds they see. Participants are asked to watch their feeders for part or all of a two-day period every two weeks, from late autumn until early spring. The information from Project FeederWatch helps scientists track bird movements and see whether some species are increasing or decreasing. There is a fee to take part.



Hopper feeder with squirrel baffle

For more information about any of the organizations or events mentioned in this chapter, see the resources section at the back of this pamphlet. Also, before going online, be sure you have your parent's permission.

The Great Backyard Bird Count takes place over a one-week period every February, with participants across the country submitting online checklists totaling 4.3 million backyard birds of more than 550 species. Like FeederWatch, this project gives scientists a snapshot of winter bird populations. Participation is free.

Project FeederWatch and the Great Backyard Bird Count are jointly run by the Cornell Laboratory of Ornithology and the National Audubon Society. For information, visit the BirdSource Web page, or write to the Cornell Laboratory of Ornithology or the National Audubon Society.

North American Breeding Bird Survey

Every summer since 1965, volunteers have surveyed singing birds along thousands of 25-mile routes throughout North America, recording how many of each species they hear. Over the years, the Breeding Bird Survey, which is coordinated by the U.S. Department of the Interior, has allowed scientists to monitor rising and falling bird populations, making it one of the most important bird surveys. Participants must be able to identify all common birds by song and must be able to drive the survey route. For more information on the BBS, visit the Patuxent Wildlife Research Center's Web site.



Western meadowlark



Songbirds western tanager, above, and ruby-crowned kinglet, right.



Bird Banding

Although federal law requires that you have a special license to band birds, banders are permitted to use volunteers who have been properly trained. Learning to band birds takes much time, patience, and maturity. Ask your local bird club, wildlife sanctuary, or merit badge counselor for recommendations of banders working in your area.





Bird Conservation

Scientists estimate that there are more than 5 billion wild birds in North America. To survive, each bird requires a special habitat for nesting, feeding, and migration.

Human activities have changed much of the country—by draining wetlands, polluting waterways, and converting forests and prairies into towns and farmland. Some birds, like American robins, adapt well to people. Others, however, are now rare, and a few have disappeared entirely.

Some birds have suffered from direct persecution by humans. Hawks and owls were once often shot by farmers who thought they were a danger to farm animals. Many groups of birds, including shorebirds, terns, and herons, were hunted nearly to extinction in the 1800s, when there were few game laws to protect them.

Sheer numbers can't always protect a species. One of the most abundant land birds in the world was the passenger pigeon, a wild dove that once numbered in the billions. So many of these birds migrated across eastern North America that their flocks blocked out the sun. When they roosted for the night in trees, the branches cracked under their weight. But in the 1800s passenger pigeons were shot constantly for food and sport and to feed livestock. There was little or no legal protection to stop the slaughter (mostly by market hunters), and by 1914 the passenger pigeon was extinct—every last one had been killed.



Passenger pigeon

Today, all wild birds are protected by laws like the federal Migratory Bird Treaty Act, passed by Congress in 1918. Strict hunting seasons and bag limits safeguard game species such as ducks, quail, and grouse. The biggest dangers today usually come from the many ways people have changed the environment, altering bird habitat or polluting it with chemicals. For instance, in the 1950s and '60s, pesticides like DDT almost wiped out some predatory birds, such as bald eagles, ospreys, peregrine falcons, and brown pelicans. After these chemicals were banned, the birds began a slow recovery that continues today. However, these destructive chemicals are still used in other parts of the world.

Hundreds of millions of birds are killed every year in collisions with glass windows, tall buildings, communication towers, wind turbines, and other structures. Towers and buildings lit up at night, when most birds migrate (and when the lights can disorient them) are especially dangerous. Finding ways to make these modern obstacles safer for birds will be critical to their long-term well-being.

Conservationists now worry about population declines in some of the country's prettiest and most popular birds, such as bobolinks, meadowlarks, and upland sandpipers. These species breed in grasslands like meadows and prairies, most of which have been plowed up for farming. Nests of grassland birds are often destroyed by farm machinery or trampled by livestock.

Forest songbirds such as tanagers, thrushes, and some warblers have also declined over wide areas, especially in the eastern United States. Many of these birds migrate in winter to Mexico, Central and South America, or islands in the Caribbean, where much of the native forest has been destroyed. Upon their return to the United States and Canada to nest, they find that forests here have been chopped into smaller and smaller pieces, making it easier for predators, such as raccoons, crows, house cats, and the parasitic brown-headed cowbird, to find and destroy their nests.

For more about extinction, see the *Environmental Science* merit badge pamphlet.

Extinct Birds

Since 1800, four species and five subspecies of North American birds have become extinct. In addition to the birds on this list, two other species, the ivory-billed woodpecker and Bachman's warbler, haven't been seen in decades and are probably extinct. Another 24 Hawaiian birds have also become extinct in the last 300 years, the most recent in 2004.

Species	Year Extinct
Labrador duck	approximately 1875
Great auk	1844
Passenger pigeon	1914
Carolina parakeet	1914
Heath hen*	1932
San Clemente Bewick's wren*	approximately 1941
Santa Barbara song sparrow*	1967
Texas Henslow's sparrow*	1980s
Dusky seaside sparrow*	1987
Po'ouli (Hawaii)	2004

*Subspecies

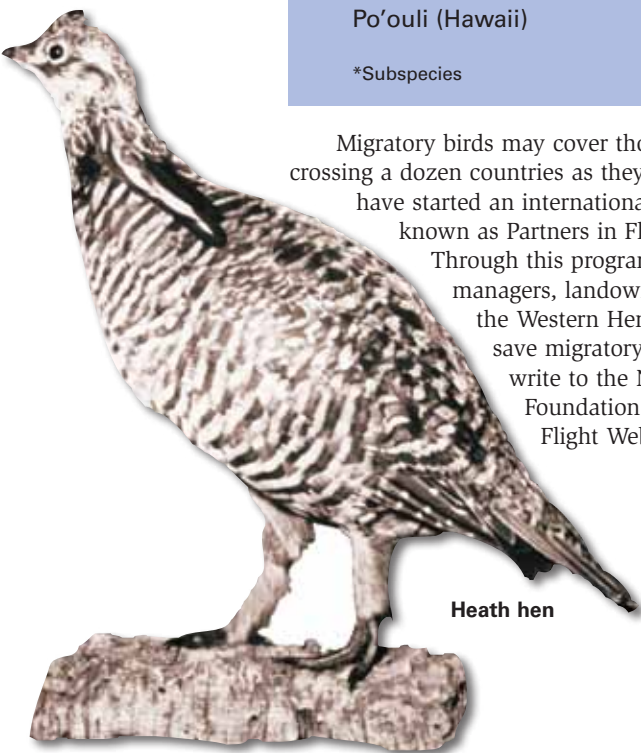

Heath hen

Migratory birds may cover thousands of miles each year, crossing a dozen countries as they travel, so conservationists have started an international program to protect them, known as Partners in Flight—Aves de las Americas. Through this program, scientists, birders, land managers, landowners, and others throughout the Western Hemisphere can work together to save migratory birds. For more information, write to the National Fish and Wildlife Foundation, or visit the Partners in Flight Web site.

Endangered and Threatened Birds

In the United States, the federal Endangered Species Act protects animals and plants that have become so rare that they may become extinct. There are two classifications: *Endangered* means the animal is in immediate danger of becoming extinct; *threatened* means that it may eventually become endangered if something is not done to help it.

The U.S. Fish and Wildlife Service, which administers the Endangered Species Act, lists these species and subspecies of birds as endangered or threatened. The following list does not include birds from Hawaii, where 30 species of birds are threatened or endangered.



Brown pelican



California condor

Birds

Brown pelican, *Pelecanus occidentalis* (except along Atlantic and eastern Gulf coasts)

Wood stork, *Mycteria americana*

California condor, *Gymnogyps californianus*

Everglade snail kite, *Rostrhamus sociabilis plumbeus*

Northern aplomado falcon, *Falco femoralis septentrionalis*

Masked bobwhite, *Colinus virginianus ridgwayi*

Attwater's greater prairie-chicken, *Tympanuchus cupido attwateri*

Light-footed clapper rail, *Rallus longirostris levipes*



Least tern

An animal or plant can sometimes be classified as endangered or threatened in one part of the country and safe in another region.

Yuma clapper rail, *Rallus longirostris yumanensis*
California clapper rail, *Rallus longirostris obsoletus*
Mississippi sandhill crane, *Grus canadensis pulla*
Whooping crane, *Grus americana*

Piping plover, *Charadrius melodus* (Great Lakes region only)

Eskimo curlew*, *Numenius borealis*

California least tern, *Sterna antillarum browni*

Least tern, *Sterna antillarum* (except for coastal populations)

Roseate tern, *Sterna dougallii* (Northeast U.S. only)

Cactus ferruginous pygmy-owl, *Glaucidium brasilianum cactorum*

Ivory-billed woodpecker*, *Campephilus principalis*

Red-cockaded woodpecker, *Picoides borealis*

Southwestern willow flycatcher, *Empidonax traillii extimus*

San Clemente loggerhead shrike, *Lanius ludovicianus mearnsi*

Black-capped vireo, *Vireo atricapillus*

Least Bell's vireo, *Vireo bellii pusillus*

Bachman's warbler*, *Vermivora bachmanii*

Golden-cheeked warbler, *Dendroica chrysoparia*

Kirtland's warbler, *Dendroica kirtlandii*

Cape Sable seaside sparrow, *Ammodramus maritimus mirabilis*

Florida grasshopper sparrow, *Ammodramus savannarum floridanus*

*Possibly extinct



Whooping crane

Threatened Birds

Steller's eider, *Polysticta stelleri*

Spectacled eider, *Somateria fischeri*

Bald eagle, *Haliaeetus leucocephalus* (except Alaska)

Audubon's crested caracara, *Polyborus plancus audubonii*

Piping plover, *Charadrius melodus* (all except Great Lakes region)

Western snowy plover, *Charadrius alexandrinus nivosus*

Roseate tern, *Sterna dougallii* (all except Northeast United States)

Marbled murrelet, *Brachyramphus marmoratus marmoratus*

Mexican spotted owl, *Strix occidentalis lucida*

Northern spotted owl, *Strix occidentalis caurina*

Florida scrub-jay, *Aphelocoma coerulescens*

Coastal California gnatcatcher, *Polioptila californica californica*

Inyo California towhee, *Pipilo crissalis eremophilus*

San Clemente sage sparrow, *Amphispiza belli clementeae*

To receive a complete, updated list of threatened and endangered animals and plants, write to the U.S. Fish and Wildlife Service, Division of Endangered Species, Mail Stop 452ARLSQ, 1849 C St. NW, Washington, DC 20240. Or, visit the agency's endangered species home page (see the resources section).

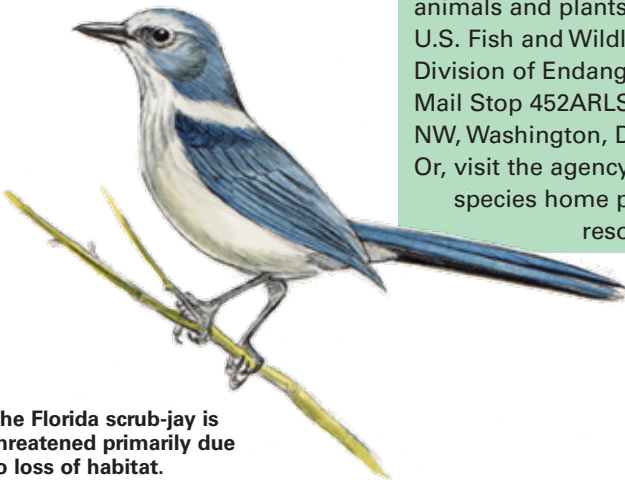

The Florida scrub-jay is threatened primarily due to loss of habitat.



Northern spotted owl. This predatory bird prefers old-growth coniferous forests.

Conservation Success Stories

While North America has lost a number of bird species since European settlement, we have also managed to save some that were once near the brink of extinction.

Uncontrolled hunting and habitat loss almost doomed the wild turkey during the 19th century. Thanks to protection and maturing forests in the East, coupled with aggressive management techniques like trapping and moving wild flocks, turkeys are now back in large numbers across almost their entire range. (Wild turkeys also have been introduced to places in the West and Hawaii, where they never originally lived, sometimes causing conflicts with native wildlife.)

In the 1960s and '70s, several predatory birds almost disappeared as a result of dangerous pesticides. One of those pesticides, DDT, interfered with their ability to lay eggs and caused the birds to lay eggs with very thin shells that were likely to break before hatching. After the chemicals were banned, the birds began a slow recovery, which continues to this day. DDT completely eliminated peregrine falcons in the East, where conservationists adapted an old falconry technique called hacking in order to reintroduce captive-bred falcon chicks into the wild. It worked so well that there are now several hundred pairs breeding in the East. Because of this recovery, the peregrine falcon was removed from the federal Endangered Species List in 1999.



The Aleutian Canada goose was removed from the Endangered Species List in 2004.

Another remarkable comeback was that of the Aleutian Canada goose, a small subspecies found in the Aleutian Islands of Alaska, but which was killed off by introduced foxes and was considered extinct for more than 25 years. Then in 1962, 300 were rediscovered on a remote island. Biologists began a long process that included removing foxes from some Aleutian Islands to create safe havens for the geese, giving them better protection on their wintering grounds in the Pacific Northwest. There are now more than 70,000 of the Aleutian Canada geese.

Declining Birds

Even though some birds have, with protection and management, returned to abundance, other formerly common birds have suffered steep declines.

One of these is the loggerhead shrike, a gray and black songbird that acts like a hawk, catching and killing insects as well as prey as large as mice, small birds, and frogs. Once abundant in farms and grasslands across the United States, shrikes began declining in the 1940s. Today they have vanished from much of their former range in New England and the mid-Atlantic region, and are rare in all but a few parts of the South, Great Plains, and Southwest. No one is sure why shrikes are in such trouble, but habitat loss and pesticide use are among the suspects.

Another grassland bird showing signs of serious trouble is the burrowing owl, which inhabits the Great Plains and deserts of the West, as well as a separate population in Florida. Burrowing owls, which are often active by day, use holes dug by prairie dogs, gopher tortoises, and other animals, and they can be quite tolerant of humans. Unfortunately, the loss of habitat to agriculture (and in Florida, to development) and the destruction of prairie dog colonies have taken a harsh toll on burrowing owls.



Burrowing owl



Creating a Backyard Bird Sanctuary

Bird conservation is a global undertaking, but you can do much to help birds in your own neighborhood—by maintaining feeders, furnishing water, building nest boxes, and growing plants that provide birds with food and cover.



Feeders

There is nothing quite as cheerful on a cold winter's day as a cloud of birds flocking to a sunflower seed feeder—jays, colorful finches, noisy chickadees, and others. A summer day is enriched by the whirring wings and flashing colors of hummingbirds drawn to a nectar feeder. The easiest way to bring birds to your backyard is by giving them something to eat. You do not need a fancy feeder, but you do need to carefully choose what foods to provide.

Seeds

To prevent the spread of disease, it is important that you keep your feeding station clean.

The single best bird food, eaten by the greatest number of species, is sunflower seed. It is accepted by everything from doves and jays to finches and sparrows. Striped seed (dark gray with white stripes) is less expensive, less nutritious, creates more waste from empty shells, and is harder for smaller birds to eat than the black-oil type.

Other seeds and nuts are good, however, for attracting particular species.

- **White proso millet:** mourning doves, sparrows, juncos
- **Thistle seed:** goldfinches, pine siskins
- **Whole raw peanuts:** jays
- **Peanut kernels:** titmice and chickadees
- **Cracked corn:** grackles, juncos, quail



If you provide nothing but sunflower seeds, you will attract many birds. There are two varieties: striped sunflower seed, *left*, and the smaller, black oil-type sunflower seed, *right*.

There are several kinds of seeds and grains that birds don't often eat: barley, rapeseed, and wheat kernels. Unfortunately, the bargain seed mixes often sold in grocery and department stores have lots of these seeds, and not many of the good varieties. Check the label. If it contains a lot of junk seeds, do not buy it.

Suet and Peanut Butter

Suet is hard beef fat, which you can buy from a butcher and hang in a tree in a plastic mesh bag (use one that onions came in) or a wire basket. Woodpeckers, nuthatches, chickadees, titmice, and wrens, among others, like suet. These same birds also enjoy peanut butter, which has fat to keep them warm during the winter. You can make a special peanut butter feeder by drilling holes in a section of a tree branch or log, or you can smear the paste on a pinecone and hang it, from its tip, in a tree. Peanut butter also can be mixed with sunflower and millet seed, rolled oats, or crushed berries.

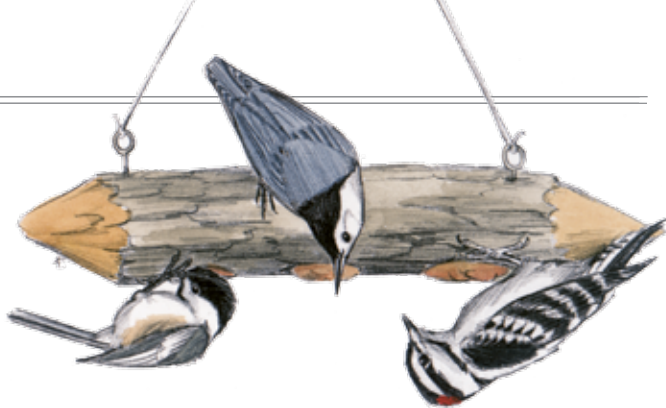

Upside-down suet feeder. Woodpeckers, chickadees, titmice, and nuthatches—all expert clingers—will freely use this homemade log suet feeder. Larger, heavier starlings, jays, and crows will be unable to steal the suet. Peanut butter may be smeared in the holes instead of suet.

Choosing a Feeder

Feeders come in a bewildering variety of sizes, shapes, and styles, but you need to know only two basic kinds. A *platform feeder* has a flat tray for the seed, often with a roof and a central storage compartment known as a hopper, which lets more seed dribble out as the birds feed. Platform feeders can be mounted on poles that are hung from trees or positioned from the ground.

Tube feeders are long plastic cylinders with small holes in the side and perches for the birds to sit on. They are made to hang from trees or poles. Not all birds can use tube feeders. They are fine for small, agile species such as chickadees, but not for larger birds such as jays or doves. This fact can be useful if you want to provide food for smaller species that are sometimes crowded out by their bigger neighbors.

You also can make simple feeders.

- Cut away part of the side of a one-gallon plastic beverage jug, leaving a 2-inch-deep shelf along the bottom. Fill the basin with seed and hang it from a tree branch.
- Make a homemade feeder from half a coconut shell. Drill four small holes around the rim for wire or monofilament hangers, and drill several drainage holes in the bottom.
- The easiest feeder is none at all. Simply scatter seed on the ground near trees, bushes, or other cover. This is best for ground-feeding birds, such as doves, sparrows, and cardinals, but makes it harder to keep the feeding area clean.

Where to Place Your Feeder

Whether or not you get lots of birds at your feeder will partly depend on where you put it. Birds need to feel secure while they are eating, in a place where a predator will not surprise them, and with thick cover nearby for them to escape to if danger appears. Look around your home. If you can, pick a place near trees or bushes but close enough to a window from which you can easily see the birds. Do not locate your feeder low to the ground or where household cats can ambush the birds.



Try not to place your feeder too close to a large window, because birds may be confused by the reflection and hit the window, hurting themselves. If this happens, see the end of this section on what to do with injured birds.

Cleaning Up

It is important, both for the birds and for yourself, that you keep your feeders and the area around them clean. Birds can contract diseases from a messy feeding station, and old, fallen seed can attract rats and other pests. Rake up and discard old seed hulls once a week. Periodically empty feeders and wash them with a solution of 1 part chlorine bleach to 9 parts water. Air dry, and then refill.



Caution: Use only white table sugar to make hummingbird nectar. Honey, molasses, or other sweeteners are prone to a fungus that can sicken or kill hummingbirds. Do not try to make the nectar sweeter by using more sugar than the recipe calls for because this can also sicken the birds. Be sure to change the nectar and clean the feeders every few days, especially in hot weather, so the sugar-water doesn't spoil.



Ruby-throated hummingbird at feeder

Nectar Feeders

Hummingbirds feed largely on plant nectar, a natural form of sugar-water that they find in flowers. You can lure them to your yard by providing homemade sugar-water in a special nectar feeder. Be sure you buy a feeder that comes apart easily so you can scrub all the parts with hot water (no soap) and a bottle brush.

To make the nectar, mix 1 part plain white table sugar with 4 parts boiling water (1 cup of sugar mixed with 4 cups of water). Then let the mixture cool while covered so the water doesn't evaporate. Refrigerate any leftover nectar. You do not have to add red food coloring to the mix—hummingbird feeders usually have red plastic around the feeder ports, which attracts the birds.

Eggshells

During spring and summer, female birds need to replenish the calcium that they use to make the shells of the eggs they lay. You can help them by saving the shells of chicken eggs your family uses. Wash the shells, break them into large pieces, and place them on a cookie tray under the broiler of your oven (ask an adult for help) until they start to turn golden brown. This sterilizes them to eliminate germs. Then break the shells into small pieces and place them on the ground near a feeder or water source, where birds will find them.

Nest Boxes

Many birds—among them bluebirds, wrens, tree swallows, titmice, chickadees, and some ducks, hawks, and owls—nest in holes in hollow trees, known as *cavities*. Unfortunately, nest cavities are hard to find in many areas or have been taken over by starlings and house sparrows. By building nest boxes with properly sized holes, you can increase the populations of native cavity-nesting birds.

The most effective nest box design is an upright rectangle with an overhanging roof and one hinged side for easy cleaning (see nest box plan). The size of the entrance hole and overall dimensions of the box vary, depending on what species you want to attract, although a box with a 1½-inch hole is ideal for a wide variety of birds, including bluebirds. Fancy or unusual designs, like those that imitate human houses, are generally not very effective or safe for the birds.

Nest Box Dimensions

Species	Hole diameter	Box height	Inside floor size
Chickadees, titmice, nuthatches, wrens	1¼"	8"	4" X 5½"
Bluebirds, tree swallows, great-crested flycatchers	1½"	9¾"	4" X 5½"
Northern flickers (The box must be tightly packed full of sawdust so the flicker can "excavate" the hole.)	2½"	24"	7¼" X 4¼"
American kestrels, screech owls, northern saw-whet owls (Cover the floor with 2 inches of coarse wood shavings, not sawdust.)	3"	14"	11¼" X 10"
Wood ducks, hooded mergansers	Oval 4" wide X 3" high	24"	11¼" X 9¾"
Common mergansers	5"	24"	11¼" X 9¾"

Eastern Bluebird Nest Box

Materials List

- Standard board 1" x 6", 4 feet long
- Standard board 1" x 10", 10½" long
- 1¾" galvanized nails, approximately 20
- Two 1¾" galvanized screws for pivot point
- One double-headed nail for holding door closed

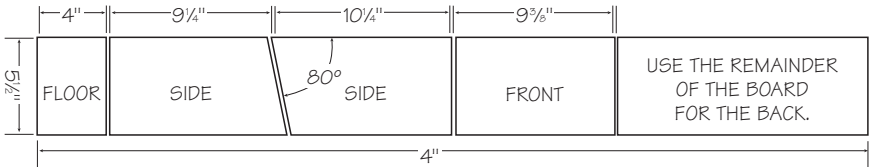
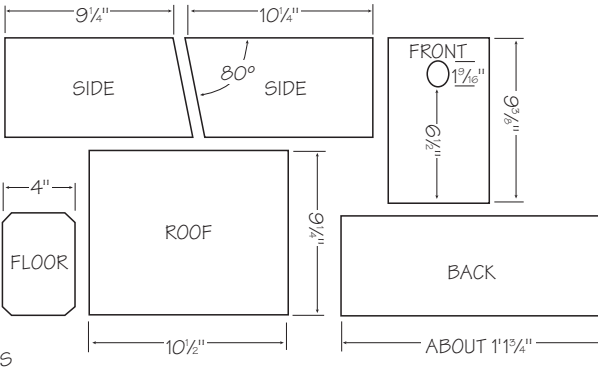
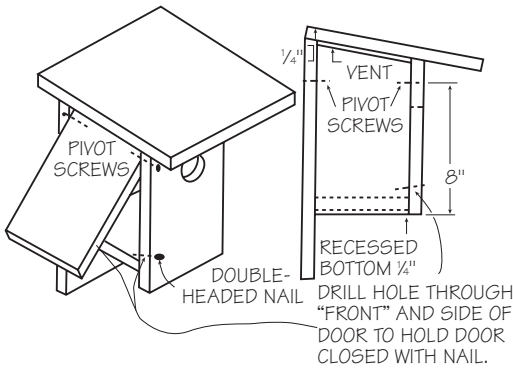

These nest box plans have been provided by the North American Bluebird Society. For more information about bluebirds and their conservation, visit the NABS Web site: <http://www.nbluebirdsociety.org>.

Use $\frac{3}{4}$ -inch, untreated lumber. (See the *Woodwork merit badge pamphlet*.) Assemble the box using galvanized screws, which hold tighter and longer than nails. Be sure to drill several $\frac{1}{4}$ -inch ventilation holes around the top of the side and back walls, and several more in the floor for drainage. It is not necessary to paint the finished box, although a coat of stain or clear waterproof sealer will help preserve the wood.

Do not paint the entrance hole or inside of the box. Do not put a perch below the hole. Native birds do not need one, and a perch makes it easier for house sparrows, starlings, and other predators to attack the birds nesting inside.

Bluebirds like nest boxes placed in open country with low-cut grass and widely spaced trees and shrubs. Chickadees, wrens, and titmice prefer woodlands. Mount the box on a steel pole 6 feet off the ground. Wrap a 24-inch-wide metal cone around the pole, or cover the pole with grease to discourage cats, raccoons, and other predators. Face the box away from the prevailing wind and rain.

Clean out boxes in late winter, removing old nesting materials, mouse nests, and other debris. During the nesting season, do weekly checks. Quickly open the hinged side, count the eggs or chicks, note anything unusual about the nest materials, and record the results in your field notebook. Then leave the area so the parents can return.

Most songbird eggs hatch two weeks after the last egg is laid, and the chicks are ready to leave the nest in 14 to 21 days. Do not disturb the nest during the last four or five days of this period, or the young birds might leave before they are ready.



Bluebird nest box



Points to Remember

- Use only untreated lumber; chemicals from treated wood may harm birds. Other materials like particle board are less durable, and metal does not insulate enough against the extremes of heat and cold. Thick lumber provides the best insulation.
- It is not necessary to stain nest boxes. If you do, use dull colors like gray or light brown. Avoid dark colors, which will make the box too hot in the sun.
- Clean out boxes after each nesting, and then inspect again in early spring prior to the nesting season. Wear gloves when removing old nesting material, and wash your hands when finished.
- Space boxes about 300 feet or more apart. If they are too close, birds of the same species will fight over territory. Where tree swallows or violet-green swallows are prevalent, try placing two boxes 10 to 30 feet apart, then 300 feet or more between the next pair of boxes. This may enable swallows and bluebirds to nest peaceably together.
- If the lumber is smooth, use a sharp nail, rasp, or file to roughen the inside of the front of the box so the fledglings can easily climb to the hole. Saw kerfs may also be etched on the inside of the front panel.
- Do not build apartment boxes, except for martins.

Starting a Bluebird Trail

Bluebirds, once rare in many parts of the country, have recovered to a remarkable degree because people build and maintain nest boxes for them. But they still need help. The best way is to set up a bluebird trail, a series of boxes placed roughly 300 feet apart across the landscape. Some bluebird trails are short, involving a few dozen boxes. Others, maintained by large groups of people, stretch across entire states and consist of thousands of boxes.

Some Scouts have organized bluebird trails for their service projects. Your local bird club or nature sanctuary can tell you whether there is a bluebird trail in your area. If there isn't a trail, consider organizing one. For more information about building, placing, and maintaining bluebird boxes, write to the North American Bluebird Society, or visit its Web site.

For more information about any of the organizations or events mentioned in this section, see the resources section at the end of this pamphlet.

Other Nest Structures

Not all birds nest in tree cavities, but some of these species can also benefit from human assistance. Robins, phoebes, and barn swallows will nest on square wooden platforms mounted beneath the eaves of barns, sheds, or buildings, out of the wind and rain. Mourning doves, which build flimsy nests, will fledge more babies if you provide them with shallow cones of metal hardware "cloth," about 10 inches in diameter and wired into a crotch in the branches of a dense tree like a pine.

Purple martins nest in colonies, usually in special "apartment house" nest boxes, or in hollow gourds. For more information on attracting martins, write to the Purple Martin Conservation Association, or visit its Web site.

If you have robins or swallows in the neighborhood, try making a small mud hole. These species need mud to cement their nests together.

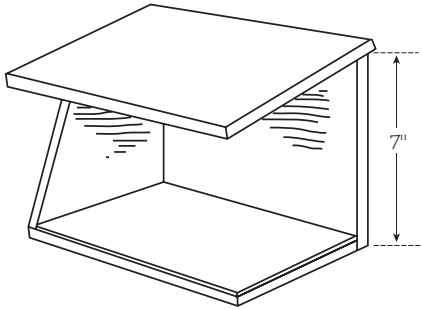

Robin Nesting Shelter

NOTES:

1. THERE IS ONLY ONE SIDE.
2. ROOF HANGS OVER SIDES AND FRONT.
3. TO ASSEMBLE:
 - A. NAIL THROUGH BACK INTO FLOOR
 - B. NAIL THROUGH SIDE INTO FLOOR AND BACK
 - C. NAIL THROUGH ROOF INTO SIDE AND BACK.

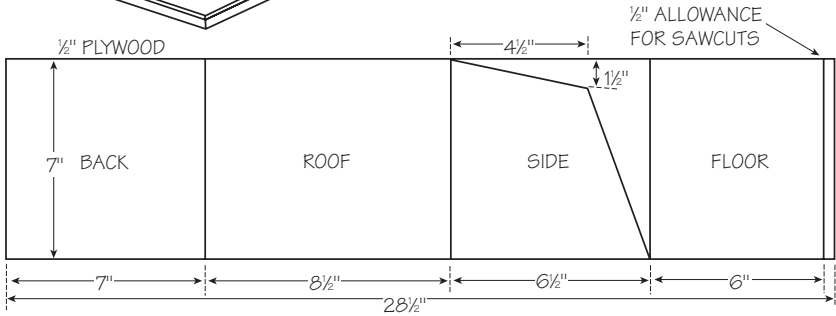

Robins will nest in shelters made with one or more sides open.

Nesting Materials



Birds collect a wide variety of natural materials—grass, plant fibers, weed stems, animal hair—from which to build their nests. They will often accept synthetic yarn or string. Be careful, though—pieces that are too long may entangle or kill the bird. Cut twine, string, yarn, or narrow strips of cloth (never use fishing line or thread) into pieces no more than 5 or 6 inches long. In spring and summer, when birds are nesting, you can simply drape these over branches where they can be found, but it's better to use a holder of some sort.

An empty wire suet basket is a good choice, as are two plastic berry baskets held together with twist ties. Be sure to pull some of the strings or strips of cloth through the holes so they dangle and flap in the breeze to attract the birds' attention.

You can also add loose cotton or cotton balls. Many birds, such as goldfinches, line their nests with soft plant down and will use the cotton instead. Clean out your family's hairbrushes, or brushes used on dogs and cats, for species such as chipping sparrows, which like to line their nests with hair.

Water

One of the best ways to attract birds to your backyard is to provide water. You do not need an elaborate garden pond. A simple, old-fashioned birdbath works well, as long as you keep it clean by scrubbing it every day or two with hot water and adding fresh water with a hose.

What works even better is just the bowl from a birdbath, or a shallow plastic dish like the kind that go under potted plants, placed directly on the ground near escape cover such as trees or bushes. Put a flat rock as big as your hand in the middle so there is only an inch or so of water over it. Some birds do not like to wade into deep water to bathe.

You can also make a temporary birdbath by digging a shallow hole in the ground, removing any sharp stones or sticks, and then lining it with heavy plastic. Place gravel on the bottom, put rocks around the edge to hide the plastic, and fill it with water.

Be sure to keep the basin clean, and change the water regularly; stagnant water may spread disease and will be a breeding place for mosquitoes that spread West Nile virus and other diseases that affect both humans and birds. For the same reason, remove old tires and other objects that collect stagnant water.

The sound of running or dripping water will bring birds from far away. An easy way to accomplish this is to fill a clean, one-gallon plastic milk jug with water. Hang it several feet above a birdbath bowl or plastic dish on the ground. Put a flat rock in the bowl, and fill the bowl with water. Unscrew the cap of the jug slightly to allow air inside. Make a tiny hole with a needle or pin in the bottom of the jug so the water drips very slowly into the basin.



Landscaping for Birds

The worst yard for birds is an empty yard, with no trees or shrubs for shelter and no berries or seeds for food. To make your yard a bird sanctuary, try to provide cover, food, and nesting spots. Keep bird feeders and birdbaths clean and well-maintained.

What kinds of plants you use will depend on where you live. Plants that grow in the hot Southwestern deserts might not tolerate a cold New England winter, for instance. Whenever possible, use flowers, shrubs, and trees that are native to your part of the country. They are best adapted to your climate, and they are the ones the local birds already use. A good place to start looking for suggestions is your county extension agent or soil conservation district. Also ask local nurseries, greenhouses, and Audubon chapters and bird clubs, since many birders also enjoy gardening for wildlife.



Keep these ideas in mind when planning a backyard sanctuary.

- Evergreen trees and shrubs, which keep their needles or leaves all year, are excellent cover for birds, especially in winter when most other plants are bare.
- Berry-producing shrubs provide cover and food for birds. The best species are those like dogwoods, spicebush, sassafras, and mulberries that produce lots of berries in summer and early autumn. Shrubs like firethorn, mountain ash, and holly are poor choices because their fruit usually has little nutritional value for birds.
- Hummingbirds are attracted to plants with long, tubular flowers, like trumpet-creeper, penstemon, bee balm (monarda), cardinalflower, and columbines. They also enjoy impatiens, salvia, and coral bells.
- Don't trim back flowerbeds after plants have died for the winter; dead stems provide cover for birds. Many native wildflowers (coneflowers, sunflowers, coreopsis) produce lots of seeds that attract goldfinches, sparrows, and other winter birds.
- Consider "planting" or leaving a dead snag—a thin, dead tree trunk 10 or 15 feet high, with a few branches still clinging to it. Many birds, including flycatchers, bluebirds, hawks, and owls, use snags for hunting perches, and woodpeckers will drill nest holes in them. A snag often attracts species you would otherwise never see in your yard.

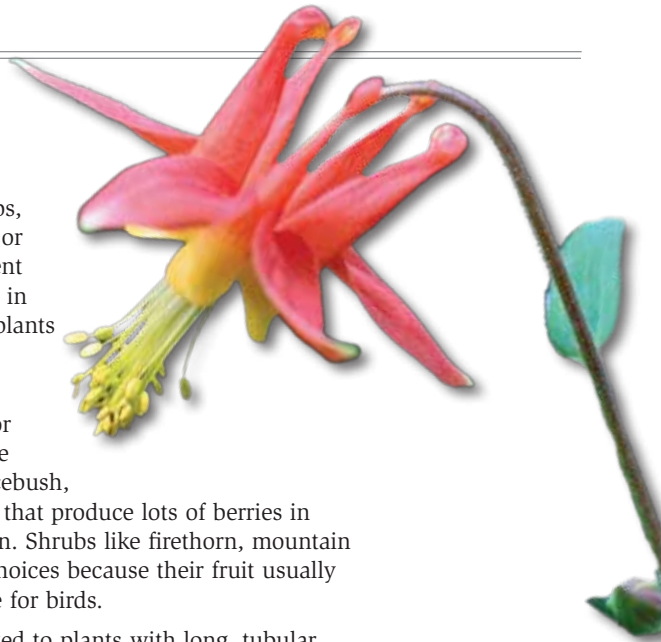

A bell on a cat's collar, an old method of warning birds, does little or no good. Birds do not associate the tinkling with danger. For more information, visit the American Bird Conservancy's Web page called "Cats Indoors!"

Backyard Hazards

Make your yard attractive to birds, and make it safe, too. House cats—even those that are well-fed or have had their claws removed—will hunt birds and should be kept indoors. Each year, many millions of birds die after flying into windows. Pesticides and other chemicals in your yard can be harmful to wild birds, especially if your yard attracts hummingbirds. Remember, birds eat many harmful insects, helping to control pests without chemicals.

Keep Cats Indoors

Experts estimate that domestic cats kill hundreds of millions of birds (and many mammals, reptiles, amphibians, and other animals) each year in the United States, making them one of the biggest hazards to wild birds. The solution is simple: Keep all pets indoors, which is better for them, and for wildlife.

The most common injury for backyard birds comes from a collision with a window. They become confused by the reflection and fly into the glass, not realizing it is solid. Large windows and sliding doors are especially dangerous. Usually the bird is simply stunned and just needs time to recover. Fold an

old hand towel and place it in the bottom of a paper bag. Gently place the bird, belly down, inside.

Leave the top of the bag slightly open, and put it outside, away from wind or rain. Then leave it alone for an hour or so. The bag will hide the bird from predators. Once the bird recovers, it will fly out on its own.

To help break up the reflection on the glass, cover the outside with fine netting. Also try making life-sized paper cutouts of owls or flying falcons (use a field guide to get the shape right) and tape them to windows to scare away birds. Some companies make weatherproof cutouts to be permanently affixed to the outside of windows.



What to Do With Injured or “Orphaned” Birds

On occasion, you may encounter an injured wild bird or a baby bird that cannot fly well and appears to be orphaned. Federal and state laws prohibit anyone without a special license from keeping wild birds, but here are some things you can do to help.

First, remember that orphaned baby birds almost never need your help. Most birds leave the nest before they are able to fly well, and the babies scatter in all directions. The parents must move among them, feeding them in turn. It is not unusual to watch a baby bird for a long time and not see the parents, but they will be back eventually to check on their chick. If you find a baby bird like this, simply leave it alone. If it is in a dangerous place—on a busy street, or where dogs or cats will soon find it—you can move it to a nearby bush or tree.

If you find a bird with a more serious injury, call your local wildlife department or a nearby sanctuary or refuge and take it to a *wildlife rehabilitator*, someone specially trained and licensed to care for wild animals. If the bird is large, drop a bath towel over it to capture it. Then place it and the towel in a large cardboard box with the top closed. The darkness inside the box will calm the bird. Do not try to feed it or give it anything to drink. Do not put the bird in a wire cage. It might break its feathers as it struggles.

Birds, like all living things, are susceptible to diseases and parasites, most of which do not affect humans. However, always wash your hands with soap and hot water after handling a wild bird. If you find a dead bird in your yard, use a plastic bag to remove it or bury it with a shovel.



Do not worry about human odor frightening off the parents. Most birds have little or no sense of smell.

It is against the law to collect wild birds, their feathers, eggs, or nests. However, some educational institutions such as museums, schools, and nature sanctuaries have special permits allowing them to keep such items. If you find an unusual dead bird, check with such an organization to see whether it can use the specimen for its collection.

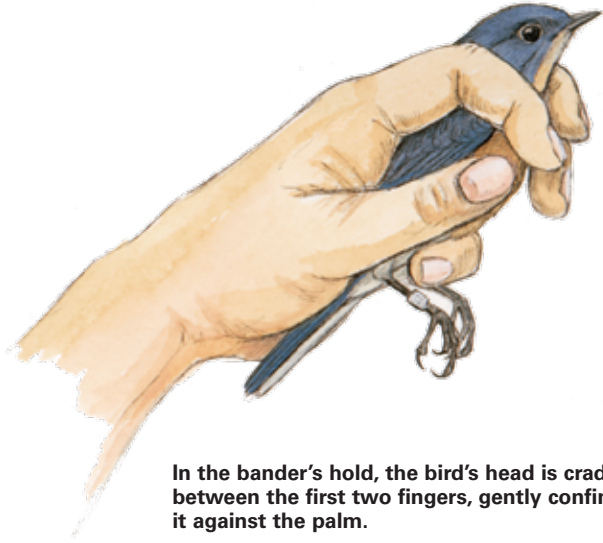

In the bander's hold, the bird's head is cradled between the first two fingers, gently confining it against the palm.

Caution: Be extremely careful around hawks, owls, or other birds of prey, which can hurt you badly with their claws. Loons, herons, and egrets may stab toward your eyes with their sharp bills. Leave the handling of these birds to the experts.





Bird Study Resources

Scouting Literature

Eastern Backyard Birds pocket guide;
Western Backyard Birds pocket guide;
Fieldbook; *Environmental Science, Fish and Wildlife Management, Forestry, Gardening, Landscape Architecture, Mammal Study, Nature, Pets, Photography, Reptile and Amphibian Study, Soil and Water Conservation, and Woodwork* merit badge pamphlets

Visit the Boy Scouts of America's official retail Web site at <http://www.scoutstuff.org> for a complete listing of all merit badge pamphlets and other helpful Scouting materials and supplies.

Field Guides

Field Guide to the Birds of North America, 4th ed. National Geographic Society, 2002.

Griggs, Jack, ed. *All the Birds of North America: American Bird Conservancy's Field Guide*. HarperCollins, 1997.

Kaufman, Kenn. *Birds of North America*. Houghton Mifflin, 2000.

———. *Field Guide to Advanced Birding* (Peterson Field Guide Series). Houghton Mifflin, 1990.

National Audubon Society First Field Guide: Birds. Scholastic Inc., 1998.

Peterson, Roger Tory. *Field Guide to the Birds of Eastern and Central North America*, 5th ed. Houghton Mifflin, 2002.

———. *Field Guide to Western Birds*. Houghton Mifflin, 1998.

———. *Peterson First Guide to Birds of North America*. Chapters Publishing Ltd., 1998.

Robbins, Chandler, Bertel Bruun, Herbert Zim, and Jonathan Latimer. *Birds of North America*. St. Martin's Press, 2001.

Sibley, David Allen. *The Sibley Guide to Birds*. Knopf, 2002.

Stokes, Donald, and Lillian Stokes. *Stokes Field Guide to Birds: Eastern Region*. Little Brown & Co., 1996.

———. *Stokes Field Guide to Birds: Western Region*. Little Brown & Co., 1996.

Other Books About Birds

- Able, Ken. *Gatherings of Angels: Migrating Birds and Their Ecology*. Cornell University Press, 1999.
- Choate, Ernest, and R. A. Paynter Jr. *Dictionary of American Bird Names*. Harvard Common, 1985.
- Cox, Randall. *Birder's Dictionary*. Falcon Publishing Co., 1996.
- Dennis, John. *A Complete Guide to Bird Feeding*. Knopf, 1994.
- Ehrlich, Paul, David Dobkin, and Darryl Wheye. *Birder's Handbook*. Fireside, 1988.
- Elbroch, Mark. *Bird Tracks and Signs: A Guide to North American Species*. Stackpole Books, 2001.
- Greenberg, Russell, and Jamie Reaser. *Bring Back the Birds*. Stackpole Books, 1995.
- Kaufman, Kenn. *The Lives of North American Birds*. Houghton Mifflin, 1996.
- Leahy, Chris. *Birdwatcher's Companion*. Princeton University Press, 2004.
- Sibley, David Allen, illustrator. *The Sibley Guide to Bird Life and Behavior*. Knopf, 2001.
- . *Sibley's Birding Basics*. Knopf, 2002.
- Thompson III, Bill. *Bird Watching for Dummies*. IDG Books, 1997.
- Welty, Joel C., and Luis Baptista. *The Life of Birds*, 4th ed. Saunders, 1997.

Recordings of Bird Calls

- Borror, Donald, and William Gunn. *Songs of the Warblers of North America*. 1985.
- Cornell Laboratory of Ornithology. *Guide to Bird Sounds*. 1985.
- Evans, William, and Michael O'Brien. *Flight Calls of Migratory Birds*. 2002.
- Peterson, Roger Tory. *Field Guide to Bird Songs: Eastern/Central North America*. 2002.
- . *Field Guide to Western Bird Songs*. 1999.
- Walton, Richard, and Robert Lawson. *Birding by Ear*. 2002.
- . *Birding by Ear: Western*. 1999.
- . *More Birding by Ear: Eastern and Central*. 2002.

Other Media

- Dunn, Jon, Sheri Williamson, and John Vanderpoel. *Hummingbirds of North America*. 2003. 180 minutes. VHS.
- Godfrey, Michael, and Kenn Kaufman. *Owls Up Close*. 1991. 55 minutes. VHS.
- Male, Michael, and Judy Fieth. *Watching Warblers: A Video Guide to Warblers of Eastern North America*. 1996. 60 minutes. VHS.
- . *Watching Sparrows*. 2002. 75 minutes. VHS.
- Nature Science Network. *Hawks Up Close*. 1992. 55 minutes. VHS.
- Porter, Diane. *How to Start Watching Birds*. 1994. 90 minutes. VHS.
- Walton, Richard, and Greg Dodge. *Shorebirds: A Guide to Shorebirds of Eastern North America*. 70 minutes. VHS and DVD.

Birding Software and CD-ROMs

AviSys 6 for Windows. Perceptive Systems, 2006. Listing software for all species, worldwide, with ability to include lengthy sighting notes.

Bird Brain 6 for Mac. Ideaform, 2009. Listing and record-keeping software.

Cornell Lab of Ornithology's Guide to Birds of North America. Thayer Birding Software, 2002. CD-ROM for PCs. Photographs and songs of all North American birds, state checklists, bird club listings, electronic version of *Birder's Handbook*, and more.

Peterson Multimedia Guides: North American Birds. Houghton Mifflin Interactive, 1996. CD-ROM for Windows. Covers all North American birds with illustrations, text from Peterson field guides, songs, photographs, and range maps.

Organizations and Web Sites

American Bird Conservancy

Telephone: 540-253-5780

Web site: <http://www.abcbirds.org>

American Birding Association

4945 N. 30th St., Suite 200

Colorado Springs, CO 80919

Toll-free telephone: 800-850-2473

Web site:

<http://www.aba.org>

BirdSource

Web site: <http://www.birdsource.org>

Cornell Laboratory of Ornithology

Web site: <http://www.birds.cornell.edu>

Hawk Migration Association of North America

Web site: <http://www.hmana.org>

Journey North

Web site: <http://www.learner.org/jnorth>

National Audubon Society

700 Broadway

New York, NY 10003

Telephone: 212-979-3000

Web site: <http://www.audubon.org>

North American Bluebird Society

P.O. Box 43

Miamiville, OH 45147

Telephone: 812-988-1876

Web site:

<http://www.nabluebirdsociety.org>

Purple Martin

Conservation Association

301 Peninsula Drive, Suite 6

Erie, PA 16505

Telephone: 814-833-7656

Web site: <http://www.purplemartin.org>

Partners in Flight

Web site: <http://www.partnersinflight.org>

Patuxent Wildlife Research Center

U.S. Geological Survey

Telephone: 301-497-5500

Web site: <http://www.pwrc.usgs.gov>

U.S. Fish and Wildlife Service

Web site: <http://www.fws.gov>

Acknowledgments

The Boy Scouts of America thanks Eagle Scout Scott Weidensaul, who wrote this updated edition of the *Bird Study* merit badge pamphlet. Weidensaul is a natural history writer, birder, and bird-bander who has written more than two dozen books on nature. His book *Living on the Wind*, about bird migration, received a Pulitzer Prize nomination.

Heartfelt thanks to Eagle Scout Gary M. Stolz, Ph.D., for his role in updating this edition of *Bird Study*. We are indebted to this longtime, dedicated Scouter, who serves as a refuge manager for the U.S. Fish and Wildlife Service. His expertise comes from his work as an affiliate professor with the University of Idaho, as an avid ornithologist and herpetologist, and as an editor of more than 50 books on natural history.

Special thanks to artist Julie Zickefoose, whose illustrations throughout this merit badge pamphlet captured the nature and details of birds so precisely. Thanks also to Eagle Scout Bob Gress, director, Great Plains Nature Center, Wichita, Kansas.

We appreciate the Quicklist Consulting Committee of the Association for Library Service to Children, a division of the American Library Association, for its assistance with updating the resources section of this merit badge pamphlet.

For their involvement with the 1999 edition of the *Bird Study* merit badge pamphlet, we are grateful to the Texas Audubon Society. In particular, thanks to Mark Shavers, who was instrumental in shaping the requirements, and to Catriona Glazebrook, former TAS president. Thanks also to Dr. Paul Green of the American Birding Association, and to Thomas A. Reeves and Mike Carlo for their review and comments.

The BSA appreciates the North American Bluebird Society for permitting us to reprint its plans for a nest box design, and for technical support with text that explains the fabrication and care of the nest box.

For their hospitality, expertise, and use of park facilities for photography, we appreciate the staff members of the Arthur R. Marshall Loxahatchee National Wildlife Refuge, Boynton Beach, Florida, and Huntley Meadows Park, Fairfax County, Virginia.

Thanks to the following Scout units for their involvement with the photography needs of this book: Troop 105 of West Palm Beach, Fla.; Troop 759 of New York, N.Y.; troops 285 and 398 of San Antonio, Texas; troops 761, 950, 956, and 970 of Sterling, Va.; Troop 254 of Bedford, Tex.; and Venture Crew 717 of Eules, Texas.

Photo and Illustration Credits

Anahuac National Wildlife Refuge,
courtesy—page 53 (*right*)

Paul Bolstad, University of Minnesota,
Bugwood.org, courtesy—
page 57 (*bottom*)

Greg Lasley Photography/Greg Lasley,
courtesy—page 25

Bob Gress, courtesy—page 47

HAAP Media Ltd., courtesy—cover
(*seagull, heron, hawk, nest*)

Mark Lockwood, courtesy—
page 33 (*bottom*)

©Photos.com—cover (*notebook/binocu-
lars, perched bird, woodpeckers, kill-
deer, owl*); pages 6, 40, 63, 74, 87–88
(*both*), and 91

Terry Spivey, USDA Forest Service,
Bugwood.org, courtesy—pages 17
and 39 (*top*)

U.S. Fish and Wildlife Service,
courtesy—pages 36, 67 (*left*), 68
(*bottom*), and 71–72 (*both*)

U.S. Fish and Wildlife Service/Tim
Bowman, courtesy—page 38 (*top*)

U.S. Fish and Wildlife Service/Donna
Dewhurst, courtesy—page 61 (*right*)

U.S. Fish and Wildlife Service/Scott
Frier, courtesy—page 67 (*right*)

U.S. Fish and Wildlife Service/Luther C.
Goldman, courtesy—page 66

U.S. Fish and Wildlife Service/John and
Karen Hollingsworth, courtesy—
page 70

U.S. Fish and Wildlife Service/Gary
Kramer, courtesy—page 61 (*top*)

Wikipedia.org, courtesy—pages 38
(*top*), 39 (*bottom*), and 72

Julie Zickefoose—all illustrations on
pages 8–11, 14–15, 18–24, 26–27, 29,
31–35, 42, 46, 48–49, 51, 54, 59–60,
64, 68–69, 76, 78, 81, 85, and 89–90

All other photos and illustrations not
mentioned above are the property of
or are protected by the Boy Scouts
of America.

John McDearmon—all illustrations on
pages 80 and 84

Brian Payne—pages 73 and 86

MERIT BADGE LIBRARY

Though intended as an aid to Boy Scouts, Varsity Scouts, and qualified Venturers in meeting merit badge requirements, these pamphlets are of general interest and are made available by many schools and public libraries. The latest revision date of each pamphlet might not correspond with the copyright date shown below, because this list is corrected only once a year, in January. Any number of merit badge pamphlets may be revised throughout the year; others are simply reprinted until a revision becomes necessary.

If a Scout has already started working on a merit badge when a new edition for that pamphlet is introduced, *he may continue to use the same merit badge pamphlet to earn the badge and fulfill the requirements therein.* In other words, the Scout need not start all over again with the new pamphlet and possibly revised requirements.

Merit Badge Pamphlet	Year	Merit Badge Pamphlet	Year	Merit Badge Pamphlet	Year
American Business	2002	Engineering	2008	Photography	2005
American Cultures	2005	Entrepreneurship	2006	Pioneering	2006
American Heritage	2005	Environmental Science	2006	Plant Science	2005
American Labor	2006	Family Life	2005	Plumbing	2004
Animal Science	2006	Farm Mechanics	2008	Pottery	2008
Archaeology	2006	Fingerprinting	2003	Public Health	2005
Archery	2004	Fire Safety	2004	Public Speaking	2002
Architecture	2008	First Aid	2007	Pulp and Paper	2006
Art	2006	Fish and Wildlife		Radio	2008
Astronomy	2004	Management	2004	Railroading	2003
Athletics	2006	Fishing	2009	Reading	2003
Automotive Maintenance	2008	Fly-Fishing	2009	Reptile and	
Aviation	2006	Forestry	2005	Amphibian Study	2005
Backpacking	2007	Gardening	2002	Rifle Shooting	2001
Basketry	2003	Genealogy	2005	Rowing	2006
Bird Study	2005	Geology	2005	Safety	2006
Bugling (see Music)		Golf	2002	Salesmanship	2003
Camping	2005	Graphic Arts	2006	Scholarship	2004
Canoeing	2004	Hiking	2007	Scuba Diving	2009
Chemistry	2004	Home Repairs	2009	Sculpture	2007
Cinematography	2008	Horsemanship	2003	Shotgun Shooting	2005
Citizenship in the		Indian Lore	2008	Skating	2005
Community	2005	Insect Study	2008	Small-Boat Sailing	2004
Citizenship in the Nation	2005	Journalism	2006	Snow Sports	2007
Citizenship in the World	2005	Landscape Architecture	2008	Soil and Water	
Climbing	2006	Law	2003	Conservation	2004
Coin Collecting	2008	Leatherwork	2002	Space Exploration	2004
Collections	2008	Lifesaving	2008	Sports	2006
Communication	2009	Mammal Study	2003	Stamp Collecting	2007
Composite Materials	2006	Medicine	2009	Surveying	2004
Computers	2009	Metalwork	2007	Swimming	2008
Cooking	2007	Model Design and Building	2003	Textile	2003
Crime Prevention	2005	Motorboating	2008	Theater	2005
Cycling	2003	Music and Bugling	2003	Traffic Safety	2006
Dentistry	2006	Nature	2003	Truck Transportation	2005
Disabilities Awareness	2005	Nuclear Science	2004	Veterinary Medicine	2005
Dog Care	2003	Oceanography	2009	Water Sports	2007
Drafting	2008	Orienteering	2003	Weather	2006
Electricity	2004	Painting	2008	Whitewater	2005
Electronics	2004	Personal Fitness	2006	Wilderness Survival	2007
Emergency Preparedness	2008	Personal Management	2003	Wood Carving	2006
Energy	2005	Pets	2003	Woodwork	2003

BOY SCOUTS OF AMERICA • SUPPLY GROUP

NATIONAL DISTRIBUTION CENTER

2109 Westinghouse Boulevard
P.O. Box 7143
Charlotte, NC 28241-7143

www.scoutstuff.org

DIRECT MAIL CENTER

P.O. Box 909
Pineville, NC 28134-0909
For fast credit card orders—

VISA, MasterCard, American Express—
call BSA operators toll-free
1-800-323-0732



NORTHERN TIER



EAGLE SCOUT



FLORIDA SEA BASE



PHILMONT SCOUT RANCH

ON THE ROAD TO HIGH ADVENTURE

THE SUPPLY GROUP IS READY TO BE A PARTNER ON YOUR TRAIL TO EAGLE THROUGH HIGH ADVENTURE. THE ADVENTURE IS YOURS, AND WE ARE READY WITH THE GEAR YOU WILL NEED. YOU CAN DEPEND ON THE LATEST IN LIGHTWEIGHT, DURABLE, QUALITY GEAR THAT WILL MEET AND SURPASS YOUR TOUGHEST REQUIREMENTS.



WWW.SCOUTSTUFF.ORG

SKU 35865



35865 2010 Printing